

# CRESSI

SINCE 1946

Manuale d'uso  
Direction for use  
Manuel d'instructions  
Bedienungsanleitung  
Manual de Instrucciones  
Руководство  
潜水呼吸调节器使用手册

erogatori  
regulators  
detendeur  
atemregler  
regulador  
пользователя  
呼吸调节器



<b>Introduction</b> .....	page 47		
<b>Main Components</b> .....	page 47		
<b>1) FIRST STAGES</b> .....	page 49	<b>3) USE AND MAINTENANCE</b> .....	page 81
1.1 T10 – T10 S.C. Cromo .....	page 50	3.1 Use of the regulator and risk assessment	page 82
1.2 MC9 - MC9 S.C. ....	page 54	3.2 Checks before use .....	page 82
1.3 MC5 .....	page 56	3.3 Mounting the regulator to the tank .....	page 83
1.4 AC2 .....	page 58	3.4 Use of the regulator in cold water .....	page 84
1.5 Performance .....	page 59	3.5 Care and maintenance of the equipment .....	page 84
 		3.5.1 Caring for the equipment .....	page 84
<b>2) SECOND STAGES</b> .....	page 63	3.5.2 Equipment maintenance .....	page 85
2.1 Master/Master Cromo/Galaxy .....	page 64	3.6 Use with Nitrox mixtures .....	page 85
2.2 Master/Master Cromo/Galaxy disassembling and maintenance .....	page 67	3.7 Maintenance/recording of procedures (Service Record) .....	page 87
2.3 XS Compact Pro / XS Compact .....	page 68	3.8 Cressi-sub Certified Combinations .....	page 88
2.4 XS Compact Pro / XS Compact Disassembly and maintenance .....	page 71	 	
2.5 XS2 .....	page 72	<b>4) TABLES</b> .....	page 321
2.6 Ellipse Octopus .....	page 73		
2.7 Ellipse, Disassembly and maintenance ...	page 75		
2.8 Performance .....	page 77		

## Introduction

Congratulations! Continual research and evolution carried out at our technical centres, together with Cressi-sub' s usual reliability, have led to the product you just purchased, which will allow you to dive comfortably and safely for a long time.

All Cressi-sub regulators are certified for use up to 50 m/55 yd. and some for use in cold water with temperatures < 10° C/50°F, having got through the strict test at 4°C/39°F (+0 -2) prescribed by the UNI EN 250:2014 according to the EC directive 89/686, which sets the essential safety requisites of Individual Protection Devices (DPI).

## Main Components

Regulators' main task is reducing the pressure of the compressed air contained in the tank to the same level as the environment' s, supplying breathable air when required by the diver. They are composed of a "first stage", working as main pressure reducer and a "second stage" (kept in the diver' s mouth), which adjusts the pressure precisely to the same value as the environment' s. The regulator is part – together with tank, valves and sling – of a complete underwater breathing system, known as "SCUBA" (Self Container Underwater Breathing Apparatus).

This handbook describes all models of Cressi-sub range, all realized in high quality materials to guarantee pleasant dives and high performance, together with the easiest ways of use and-maintenance. The instructions and directions found in this manual are based on the most up-to-date information about the equipment available before printing.

Cressi Sub reserves the right to make changes at any time.

**NOTE:** This handbook does not replace a diving training course! All Cressi-sub devices must be used by divers who have attended regular courses held by certified trainers.

Using underwater devices without a licence or the necessary technical training may be dangerous for the diver' s safety and life itself.

Besides, in order to guarantee the maximum safety, the devices must be serviced only by the producer or an authorized-centre.

**You can find your authorized Cressi-Sub center by asking your dealer, or Cressi Sub S.p.A. itself (email: info@cressi-sub.it).**

**⚠ WARNING: CRESSI-SUB DECLINE ANY RESPONSIBILITY FOR ANY SERVICING CARRIED OUT BY UNAUTHORIZED PERSONNEL.**

**⚠ WARNING: SCUBA devices complying with EN 250:2014 standard must not be used by more than a diver at the same time.**

**⚠ WARNING: in case the components of a SCUBA are set and used by more than a diver at the same time, their performance in cold water might not satisfy the requisites prescribed by EN 250:2014 standard.**

**⚠ WARNING: if the components of the SCUBA equipment are configured and used simultaneously by multiple divers, the equipment may not be used at depths of greater than 30 meters, or at water temperatures below 10 °C (if specified).**



*Direction for use regulators*  
**FIRST STAGES**

- 1.1 - T10 S.C. - T10 S.C. Cromo**
- 1.2 - MC9 - MC9 S.C.**
- 1.3 - MC5**
- 1.4 - AC2**

### 1.1. - T10 S.C. - T10 S.C. Cromo

The T10 balanced diaphragm first stage features a lightweight structure of compact design, protected by the special and innovative PVD (Physical Vapor Deposition) treatment, which creates a highly resistant surface coating with extraordinary chemical-physical characteristics and a high technical, very pleasing appearance. Unlike the T10 version, the Cromo version uses a chromed surface coating for protection.

The ergonomics of the T10 balanced diaphragm first stage presents the functioning mechanism arranged perpendicular to the air entry axis that thereby forms a “T” profile designed to guarantee perfect arrangement of the HP and LP hoses, avoiding interference with the equipment connected to the first stage; reduced size (particularly used in the SC version particularly suited to cold water), as well as additional inspection capacity and access to the HP valve mechanism to simplify maintenance and disassembling of the regulator.

It provides outstanding respiratory performance, constant in any use condition, thanks to the compensated diaphragm mechanism that enables maximum respiratory comfort to be obtained during any dive phase, from the surface to maximum depths. In fact, the regulator provides the same intermediate pressure independent of the pressure contained in the tanks and maintains performance at any depth.

Contrary to most regulators currently on the market, offering optimum performance when the tank is full at maximum working pressure, the T10 first stage was designed to offer optimum performance when the tank is close to empty.

This **“hyper balancing”** feature was possible using a system that adapts intermediate pressure taking into account the air density as the depth increases and the progressive increase in pressure drop as the tank empties.

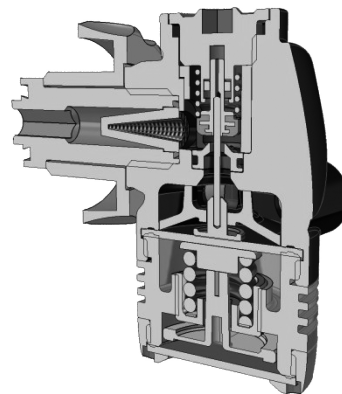

fig. 1

Thanks to this feature, the T10 first stage assists the diver in the dive, guaranteeing the highest working performance which increases further during the notoriously critical surfacing phase of surfacing.

The compensated diaphragm mechanism phase, with a “T” air entry, or rather the HP valve arranged perpendicular to the air entry axis further guarantees considerable passage of air quantity with a pressure drop, between the inhalation and exhalation phase, which is reduced considerably.

These characteristics are the result of innovative technical solutions in the design and make the 1st stage among the smallest and lightest regulators on the market and one of the top performing in its category.

In this first stage (Fig. 1), the flexible diaphragm protects and seals the mechanism inside the system and transmits pressure variations in the water to the high pressure valve.

The HP poppet valve, which is extremely resilient and easily replaced during periodic maintenance, is manufactured in the latest generation thermoplastic elastomers. This valve boasts the exclusive feature of sliding inside a special lined cylinder, also manufactured in self-lubricating thermoplastic material. The inner surface of this cylinder, which is completely free of oxidation phenomena, drastically reduces friction and makes the valve stroke extremely fluid and precise, guaranteeing optimum respiratory comfort. The HP poppet valve can also work perfectly guided on a pneumatic seal compartment, guaranteed to last long thanks to the special design of the piston sleeve that hinges the valve, without even making it rotate on its own axis. By doing so, the 1st stage performance can be kept constant and unchanged over time.

The HP valve closure nozzle, manufactured in stainless steel 316, is interchangeable to facilitate periodic maintenance of the 1st stage.

Air entry in the first stage is protected by a sintered conical filter in compact, sintered and nickel-plated phosphor bronze microspheres, to enable better air filtering thanks to the broader filtering surface guaranteed by the shape which also guarantees the passage of an elevated air flow, typical of this regulator and withholds any impurities from tank and valve.

The intermediate pressure regulation system of the T10 balanced diaphragm 1st stage follows the tradition of all Cressi-sub first stages, allowing convenient and fast regulation of intermediate pressure without having to disassemble parts of the regulator.

**⚠ WARNING:** *intermediate pressure regulation should only be carried out by authorised Cressi-sub centres and the calibration values CANNOT and MUST NOT be changed by the user, to avoid prejudicing the good working order of the regulator. We cannot be held in any way liable for any intervention carried out by staff unauthorised by Cressi-sub.*

**The Cressi-Sub authorised centres can be indicated by retailers or, alternatively by Cressi Sub s.p.a. (email: info@cressi-sub.it).**

The balanced diaphragm first stage features a lightweight structure of compact design, made from seagoing brass, protected on the surface by means of a PVD (Physical Vapor Deposition) treatment (version T10SC) or coated with chromed copper (version T10 S.C. Cromo); the interior components are made of stainless steel, chromed brass and new generation thermoplastic resins.

It avails of 4 low pressure (LP) 3/8" ports, adequately angled for optimal distribution of the hoses that avoid interference with the attached equipment, and 2 high pressure (HP) 7/16" ports with a micrometric perforation for air release, ensuring maximum safety also in the event of accidental breakage of the high pressure hose, avoiding the risk of rapid tank emptying.

**⚠ WARNING:** *on the HP ports of the first stage, an underwater gauge and/or an underwater computer must be connected to also incorporate the gauge function. Since the tanks are not equipped with a reserve device, it is absolutely indispensable to use a gauge that indicates progressive air consumption when diving and which clearly highlights the reserve pressure has been reached, which should be considered as unusable air for the purpose of the dive itself, but only as an emergency air reserve. Diving without a gauge is dangerous because there is no way of controlling consumption and you can suddenly find yourself without air during a dive, putting your life in serious danger.*

Connection of the first stage to the tank valve can take place using an international connection, using a new yoke with an extremely modern design or a threaded coupling DIN 300 bar, both according to EN ISO 12209 as referenced in the standard EN 250:2014.

As with all regulators in the Cressi-sub range, the T10 first stage offers the possibility of making certain manufacturing components of the regulator compatible, allowing interchanging parts with other diaphragm first stages in the current range.

Use of the T10 balanced diaphragm first stage is advised, compared to the piston models, for diving in waters full of suspended particles or dissolved mineral salts, or for use in cold water (with temperatures under 10°C), because all parts of the regulator mechanism are insulated for contact with water.

For diving in extreme conditions we recommend using combinations with the T10SC or the T10 Cromo SC versions equipped with the Seal Chamber (S.C.)

**⚠ WARNING:** *to deal with diving in cold water (temperature <10°C or < 50°F) Cressi-sub recommends use of a tank equipped with a pillar valve with two independent ports outlet, where two complete regulators can be connected.*

**⚠ WARNING:** *adequate technical preparation is necessary to deal with diving in cold water (temperature <10°C or < 50°F). Cressi-sub recommends you carry out this type of diving after taking a specific course given by qualified instructors. It is important not to wet the regulator before use and then expose it to air (which can be well under zero degrees). Do not use the purge button, particularly with the regulator level with Venturi effect in the "dive" position. If possible, keep the regulator in warm surroundings when not in use.*

The Seal Chamber is used to make the T10 balanced diaphragm first stage completely waterproof, avoiding water entry not only inside, but also in contact with the diaphragm and the calibration spring on the 1st stage, thereby creating an air chamber upstream of the regulator and its components, working like a proper thermal barrier. All problems are therefore avoided relating to contact with water full of suspended particles, sand, dissolved mineral salts and with cold water which, especially at temperatures below 10°C could form the foundation for possible freezing of the regulator.

The Seal Chamber (fig.2) consists of a special metal insert with a particular "radiator" shape designed to increase thermal ex-

change between the ambient temperature and the temperature inside the regulator, preventing its possible freezing effect, and a metal cap containing a silicone membrane inside. This, on warming of the ambient pressure variations, inverts and thereby transmits oscillations to the ambient pressure transducer beneath which, coming in contact with the main diaphragm, acts as a transmission element which transfers all information on the extreme pressure variations to the diaphragm. The main diaphragm which, in turn, protects and seals the mechanism inside the system, then transmits the pressure variations of the water to the high pressure valve.

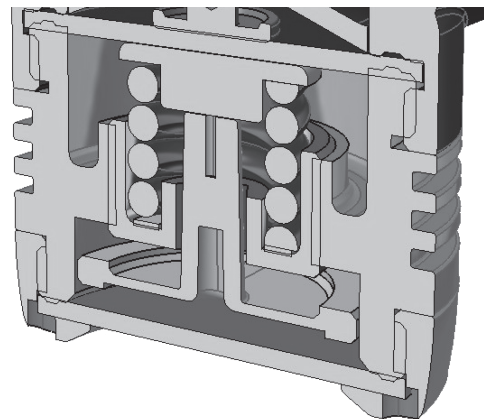

fig. 2

**⚠ NOTE:** *before assembling the **Seal Chamber S.C.** the balanced diaphragm first stage must be calibrated. To ensure the regulator works properly, strictly comply with the calibration values outlined in the regulator performance table. Regulator calibration is not restricted by the ambient pressure variations transmission disk.*

**⚠ WARNING:** *intermediate pressure adjustment should only be carried out by authorised Cressi-sub centres and the calibration values CANNOT and MUST NOT be changed by the user, to avoid prejudicing the good working order of the regulator. We cannot be held in any way liable for any intervention carried out by staff unauthorised by Cressi-sub.*

**The Cressi-Sub authorised centres can be indicated by retailers or, alternatively by Cressi Sub s.p.a. (email: [info@cressi-sub.it](mailto:info@cressi-sub.it)).**

The T10 first stage therefore can be used in cold water (with a water temperature under 10 °C), since it complies with Directive 89/686/EEC dated 21/12/1989, checked and certified by the Test Authority No. 0474 RINA located in Genoa, tested in compliance with standard EN 250:2014 that establishes the Personal protective Equipment (PPE) category III, requirements and therefore outlines the CE marking followed by identification of the certification authority (0474) pursuant to Art. 11A of the Directive 89/686/EEC.

The considerable technical solutions, combined with the high quality of the materials used, ensure that this first stage regulator is fully reliable and capable of providing the highest performance extended over time.

Additional important information relating to our equipment can be found on the website [www.cressi.com](http://www.cressi.com)



### 1.2 - MC9 - MC9 S.C.

The MC9 - MC9 S.C. balanced diaphragm first stage features a lightweight structure of compact design, enclosed in an “aesthetic-protective” shell made from a special elastomer, specially conceived to protect the regulator from impact.

It guarantees high breathing performance in every condition, thanks to its balanced diaphragm mechanism, allowing the maximum breathing comfort in every diving phase, starting from the surface up to the maximum depth. The regulator, in fact, supplies the same intermediate pressure independently from the tank pressure, and keeps its performance independently from the depth.

Unlike the most regulators on the market, offering their best performance when the tank is loaded at its maximum working pressure, MC9 first stage was designed to give its best performance when the tank is about to empty. This “**hyper-balancing**” feature is possible thanks to a system of regulation of the intermediate pressure, which takes into account both the air density as the depth increases and the progressive pressure decrease due to the tank running down.

Thanks to this feature, MC9 first stage highest assists the diver during the whole dive, guaranteeing the highest performance, which improves during the most critical phase of surfacing.

Moreover, the balanced diaphragm mechanism, delivering air “online”, allows remarkable amounts of air to pass, by a very small pressure decrease between inhalation and exhalation phases.

These features are the results of several innovating technical solutions taken by designing MC9 1st stage, making it one of the best performing small and light regulators on the market.

In this first stage (fig. 1), the elastic diaphragm protects and seals the system’s inner mechanism, transmitting the changes of water pressure to the high pressure valve.

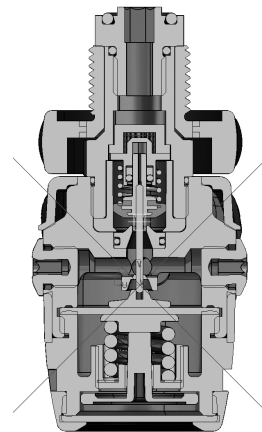

fig. 3

The latter is made of special thermoplastic state-of-the-art elastomers, is highly resistant and easily replaceable. It boasts the exclusive innovation of sliding inside a special self-lubricating cylinder in a special thermoplastic material. The cylinder’s inner surface is completely free of oxidation, reduces any friction dramatically and makes the valve slide in an extremely easy and precise way, guaranteeing the highest breathing comfort.

The HP seat is made of 316 stainless steel and is interchangeable, in order to make the maintenance of the 1st stage easier.

The passage of air through the first stage is protected by a special cup-shaped conical sintered filter, retaining any impurity from tank and valves.

The regulation system of intermediate pressure in MC9 balanced diaphragm first stage is the same as all other Cressi-sub first stages, which allows an easy and quick adjustment of intermediate pressure without having to disassemble any component of the regulator.

**⚠ WARNING:** *intermediate pressure must be set only at authorized Cressi-sub centres; the setting values must NOT and can NOT be modified by the user, in order not to affect the good working of the regulator. Cressi-sub decline any responsibility for any intervention carried out by unauthorized personnel.*

**You can find your authorized Cressi-Sub center by asking your dealer, or Cressi Sub S.p.A. itself (email: [info@cressi-sub.it](mailto:info@cressi-sub.it)).**

Balanced diaphragm first stage features a light compact structure in chromium-plated brass with inner components in stainless steel, chromium-plated brass and state-of-the-art thermoplastic resins. It is supplied with four low pressure (LP) 3/8" ports - specially angled to allow the best hose positioning, avoiding any encumbrance among different devices - and two high pressure (HP) 7/16" ports with a micrometric air exit hole, guaranteeing maximum safety even in the case of damage to the high pressure hose, since it greatly reduces air loss from the tank.

**⚠ WARNING:** *an underwater pressure gauge or a computer with such function must be connected with the HP ports of the first stage.*

*Since the tanks are not supplied with a reserve device, a pressure gauge must always be used, reporting the progressive air consumption by diving and the reaching of reserve pressure, which has to be considered as not to be used by diving but only as emergency air supply.*

*Diving without any gauge is dangerous, since the diver can not control his own air reserve, which might suddenly run out, at his own high risk.*

The first stage can be connected to the tank valve with an international, by means of an extremely modern designed bracket, or with a threaded connection DIN 300 (EN ISO 12209) bar, both complying with EN 250:2014 standard.

Like all Cressi-sub regulators, whose components are often interchangeable one with the other, MC9 is compatible with other diaphragm first stages of the present range.

MC9 balanced diaphragm first stage, like other Cressi-sub diaphragm first stages as well, is to be recommended rather than other piston models, by diving in suspension or mineral salts rich water, or in cold water at temperature lower than 10 °C/50 °F. All inner-components of the regulators are in fact perfectly watertight. For diving in extreme conditions we recommend using combinations with the MC9SC version, equipped as standard with the Seal Chamber (S.C.).

**⚠ WARNING:** *In case of dives in cold water (temperature less than 10°C/50° F), Cressi-sub recommend to use a tank supplied with a valve featuring two separate outlet ports, with which two complete regulators are to be connected.*

**⚠ WARNING:** *diving in cold water at temperature lower than 10°C/50° F requires a special technical training. Cressi-sub recommend such diving only after attending a special training course by certified trainers. The regulator must absolutely not get wet and exposed to freezing air before use. Do not press the discharge button, particularly when the Venturi effect adjustment lever is on "dive". If possible, keep the regulator in a warm place before use.*

The Seal Chamber's task is to make MC9 balanced diaphragm first stage perfectly watertight, preventing water from seeping inside or on the diaphragm and the main spring: it works as an air chamber above the regulator and its components, like a real thermal barrier. It avoids any problem caused by contact with suspension, sand, mineral salts rich water and with cold water, which might eventually cause the regulator to freeze, especially at temperature lower than 10° C/50° F.

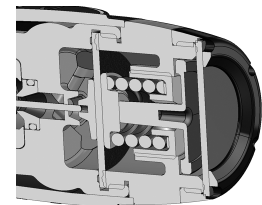

fig. 4

The Seal Chamber is composed of a metal cap containing a silicon seal. The seal responds to any environmental pressure change bending towards the inside and transmitting it to the underlying plate; the latter transmits such information to the main diaphragm. The main diaphragm protects and seals the device's inner mechanism, transmitting pressure changes to the high pressure valve.

**NOTE:** before assembling the **Seal Chamber S.C.** the balanced diaphragm first stage must be set. In order to get the regulator to work perfectly, the setting values must be strictly those reported in the regulator's performance table. The setting is independent from the plate transmitting environmental pressure changes.

**⚠ WARNING:** *intermediate pressure must be set only at authorized Cressi-sub centres, while the setting values can NOT and must NOT be modified by the user, in order not to affect the regulator's performance. Cressi-sub decline any responsibility for any intervention carried out by unauthorized personnel.*

**You can find your authorized Cressi-Sub center by asking your dealer, or Cressi Sub S.p.A. itself (email: [info@cressi-sub.it](mailto:info@cressi-sub.it)).**

MC9 first stage can be therefore used in cold water (at temperature lower than 10 °C/50 °F), complying with 89/686/EEC directive of 21/12/1989, checked and certified by N. 0474 RINA – Genoa, with tests in accordance with EN 250:2014 standard, which provides the requisites of III class Individual Safety Devices: the device therefore is EC branded and reports the certifying institute indication (0474), as prescribed by Art. 11A of 89/686/EEC directive.

Its remarkable technical features, together with its high quality materials, make this first stage a highly reliable regulator, guaranteeing best performances for a long time.

Visit our web-site [www.cressi.com](http://www.cressi.com), where you can find further information relating to your safety.

### 1.3 – MC5

MC5 balanced diaphragm 1st stage features an extremely light and compact structure enclosed in an “esthetical-protective” shell of a special elastomer, designed to protect the regulator from collision.

It guarantees high breathing performance in every condition, thanks to its balanced diaphragm mechanism, allowing the maximum breathing comfort in every diving phase, starting from the surface up to the maximum depth. The regulator, in fact, supplies the same intermediate pressure independently from the tank pressure, and keeps its performance independently from the depth.

The balanced diaphragm mechanism, delivering air “on line”, allows remarkable amounts of air to pass, by a very small pressure decrease between inhalation and expiration phases.

These features are the results of innovating technical solutions taken by designing MC5 1st stage, making it one of the best performing small and light regulators on the market.

In this first stage (fig. 5), the elastic diaphragm protects and seals the system's inner mechanism, transmitting the changes of water pressure to the high pressure valve.

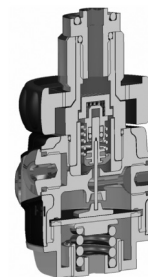

fig. 5

The latter is made of special thermoplastic state-of-the art elastomers, is highly resistant and easily replaceable. It boasts the exclusive innovation of sliding inside a special self-lubricating cylinder in a special thermoplastic material. The cylinder's inner surface is completely free of oxidation, reduces any friction dramatically and makes the valve slide in an extremely easy and precise way, guaranteeing the highest breathing comfort.

The passage of air through the first stage is protected by a special cup-shaped conical sintered filter, retaining any impurity from tank and valves.

The regulation system of intermediate pressure in MC5 balanced diaphragm first stage is the same as all other Cressi-sub first stages, allowing an easy and quick adjustment of intermediate pressure without having to disassemble any component of the regulator.

**⚠ WARNING:** *intermediate pressure must be set only at authorized Cressi-sub centres, while the setting values can NOT and must NOT be modified by the user, in order not to affect the regulator's performance. Cressi-sub decline any responsibility for any intervention carried out by unauthorized personnel.*

**You can find your authorized Cressi-Sub center by asking your dealer, or Cressi Sub S.p.A. itself (email: [info@cressi-sub.it](mailto:info@cressi-sub.it)).**

Balanced diaphragm first stage features a light compact structure in chromium-plated brass with inner components in stainless steel, chromium-plated brass and state-of-the-art thermoplastic resins.

It is supplied with three low pressure (LP) 3/8" ports - specially angled to allow the best hose positioning, avoiding any encumbrance among different devices - and a high pressure (HP) 7/16" port with a micrometric air exit hole, guaranteeing maximum safety even in the case of damage to the high pressure-hose, since it prevents the tanks from emptying.

**⚠ WARNING:** *an underwater pressure gauge or a computer with such function must be connected with the HP port of the first stage. Since the tanks are not supplied with a reserve device, a pres-*

*sure gauge must always be used, reporting the progressive air consumption by diving and the reaching of reserve pressure, which has to be considered as not to be used by diving but only as emergency air supply.*

*Diving without any gauge is dangerous, since the diver can not control his own air reserve, which might suddenly run out, at his own high risk.*

The first stage can be connected to the tank valve with an international, by means of an extremely modern designed bracket, or with a threaded connection DIN 300 bar (4350 psi) (EN ISO 12209), both complying with EN 250:2014 standard.

Like all Cressi-sub regulators, whose several components are interchangeable one with the other, MC5 is compatible with other diaphragm first stages of the present range.

MC5 balanced diaphragm first stage, like other Cressi-sub diaphragm first stages, having all inner components watertight, is to be recommended, rather than other piston models, by diving in suspension or mineral salts rich water.

The MC5 conforms to directive 89/686/EEC of 21/12/1989, having been tested and certified by Notified Body number 0474, RINA, with registered office in Genoa, with a test conducted pursuant to standard EN 250:2014 which specifies the requirements for class III personal protection equipment (PPE), and therefore carries the CE mark followed by the ID data of the notified body (0474) pursuant to Art. 11 of directive 89/686/EEC.

The appreciable technical solutions employed, combined with the high quality of the materials used, make this first stage into a highly reliable regulator, ensuring extremely high performances over a very long service life.

Its remarkable technical features, together with its high quality materials, make this first stage a highly reliable regulator, guaranteeing best performances for a long time.

Visit our web-site [www.cressi.com](http://www.cressi.com), where you can find further information relating to your equipment.

## 1.4 - AC2



fig. 6

AC2 regulator has the task to reduce the tanks' pressure. It is connected to the second stage by means of a hose supplying the diver with breathable air at environmental pressure. The first stage's main task is therefore to reduce the tanks' air to an intermediate pressure, about 10 bar (145 psi) higher than the environmental.

Small dimensions, light weight, extremely simple structure, special sturdiness and easy maintenance: here are the main features of this in-line first stage, offering as high performances as a balanced piston model's. Its compact and attractive design features four low pressure 3/8" ports in pairs, with preset angles to allow easy connection with any accessory equipment. The setting is easily performed thanks to the special revolving ring system, allowing a quick, precise and continuous adjustment, without having to disassemble the regulator.

**⚠ WARNING:** *intermediate pressure must be set only at authorized Cressi-sub centres; the setting values must NOT and can NOT be modified by the user, in order not to affect the good working of the regulator. Cressi-sub decline any responsibility for any intervention carried out by unauthorized personnel.*

**You can find your authorized Cressi-Sub center by asking your dealer, or Cressi Sub S.p.A. itself (email: [info@cressi-sub.it](mailto:info@cressi-sub.it)).**

Inside, a conical filter provides a filtering action 200% higher than a standard flat filter.

Airflow capacity is remarkable, due to new larger air ports, offering unequalled performance in this class of regulators.

Both international yoke and DIN (at 200 or 300 bar) (2900÷4350 psi) connection are fully interchangeable and are replaced with each other very quickly (only at authorized Cressi-sub centres).

Its satin finish guarantees the regulator's best surface performance, while contributing to its outstanding strength and reliability. The first stage is manufactured with the finest materials and Cressi-sub experience.

The first stage can be connected with the tank's valve either with an *international* through an *extremely modern designed* bracket, or with a threaded connection DIN (EN ISO 12209), both complying with EN 250:2014 standard. Should the tank used have a working pressure higher than 200 bar (2900 psi), a DIN connection is recommended.

Besides its technical innovations, this first stage differs from previous models as to its new esthetical look, enriched with careful particulars in its finishing as well. It is a top quality high technology regulator, showing a pleasant as well as aggressive look, united with outstanding sturdiness and easy mechanics, which allows an easy and simple maintenance.

AC2 first stage complies with 89/686/EEC directive of 21/12/1989, checked and certified by N. 0474 RINA - Genoa, with tests in accordance with EN 250:2014 standard, which provides the requisites of III class Individual Safety Devices: the device therefore is EC branded and reports the certifying institute indication (0474), as prescribed by Art. 11A of DE 89/686/EEC directive.

Its remarkable technical solutions, together with high quality materials, make this first stage a highly reliable regulator, offering top quality performance for a long time.

Visit our web-site [www.cressi.com](http://www.cressi.com), where you can find further information relating to your equipment.



*Direction for use regulators*

## **1.5 - Performance First Stages**

## 1.5 - Performance

<b>T10 / T10 S.C.</b>	
Working pressure (INT connection)	0÷232 bar
Working pressure (DIN connection)	0÷300 bar
Calibration pressure (with 200 bar supply)	10 bar
Air supply	4500 l/min (*)
High pressure (HP) ports	2
Low pressure (LP) ports	4
Weight without hose T10 SC	720 gr (INT) - 602 gr (DIN)

(\*) Values measured on LP port with second stage connected and 200 → 150 bar pressure in the tanks.

<b>MC9 / MC9 S.C.</b>	
Working pressure (INT connection)	0÷232 bar - (0÷3365 psi)
Working pressure (DIN connection)	0÷300 bar - (0÷4350 psi)
Calibration pressure (200 bar feeding)	10 bar - (145 psi)
Air supply	4500 l/min (*)
High pressure (HP) ports	2
Low pressure (LP) ports	4
Weight without hose MC9	590 gr (INT) - 450 gr (DIN)
Weight without hose MC9 SC	650 gr (INT) - 510 gr (DIN)

(\*) Values measured at LP port with second stage connected and tank pressure at 200 → 150 bar (2900 → 2175 psi)

<b>MC5</b>	
Working pressure (INT connection)	0÷232 bar - (0÷3365 psi)
Working pressure (DIN connection)	0÷300 bar - (0÷4350 psi)
Calibration pressure (200 bar feeding)	10 bar - (145 psi)
Air supply	3000 l/min (*)
High pressure (HP) ports	1
Low pressure (LP) ports	3
Weight without hose MC5	450 gr (INT) - 350 gr (DIN)

(\*) Values measured at LP port with second stage connected and tank pressure at 200 → 150 bar (2900 → 2175 psi)

## 1.5 - Performance

AC2	
Working pressure (INT connection)	0÷232 bar - (0÷3365 psi)
Working pressure (DIN connection)	0÷300 bar - (0÷4350 psi)
Calibration pressure (200 bar feeding)	10 bar - (145 psi)
Air supply	2100 l/min (*)
High pressure (HP) ports	1
Low pressure (LP) ports	4

(\*) Values measured at LP port with second stage connected and tank pressure at 200 → 150 bar (2900 → 2175 psi)





*Direction for use regulators*  
**SECOND STAGES**

- 2.1 - Master / Master Cromo / Galaxy**
- 2.2 - Master / Master Cromo / Galaxy, disassembling and maintenance**
- 2.3 - XS Compact Pro / XS Compact**
- 2.4 - XS Compact Pro / XS Compact, disassembly and servicing**
- 2.5 - XS2**
- 2.6 - Ellipse Octopus**
- 2.7 - Ellipse, disassembling and maintenance**

## 2.1. - Master / Master Cromo / Galaxy



fig. 7

Cressi-Sub's range of second-stage balanced regulators is composed of revolutionary, lightweight, elliptical, pneumatically balanced regulators (the adjustable version Master, only weighs 207 gr - the lightest in its category!). Their futuristic designs present many innovative patented features and are available in two different versions: Master (Fig. 7) (adjustable) and Galaxy (Fig. 8) (non-adjustable).



fig. 8

Both versions provide air on-demand, i.e. only when the diver inhales through the mouthpiece, generating slight negative pressure inside the regulator - it needs to be as light as possible so as not to cause undue respiratory exertion. The special adjustable elliptical

diaphragm reacts to the negative pressure; it is designed to increase its usable surface accordingly, in order to keep the breathing effort to the absolute minimum. This regulator's level of performance is guaranteed to be similar - if not superior - to any other regulator of a bigger in size.

The diaphragm gets sucked back inside the casing and brings the central disc - made of state-of-the-art friction-proof thermoplastic - into contact with the new lever designed with revolutionary geometrics in order to enhance performance and drastically reduce friction.

The lever is subsequently lowered and in doing so, opens the valve. Cressi-Sub's range of second-stage balanced regulators are equipped with a pneumatically balanced piston with a hole of minimal diameter going through it lengthwise.

The air from the first-stage comes through this hole and enters a small chamber (called the "balance chamber") positioned at the edge of the piston.

The air contained in this chamber exercises a level of pressure which varies according to the depth of the water and pushes the closing piston towards the valve nozzle. This way, a certain balance is reached between the pressure that arises when the valve opens and closes so that a low-load carrying spring can be used so that no effort whatsoever is involved in opening the valve.

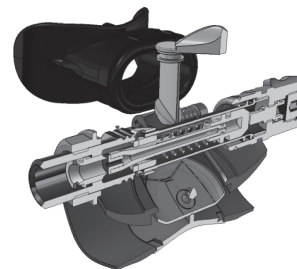

fig. 9

The pressure of the air flowing through the nozzle generates a reaction on the part of the pad, which subsequently opens. The pad is perforated as well and placed at the edge of the shaft, where the pressure is contrasted by the combined force of the spring and the air penetrating the balance chamber.

The end result of this in practical terms is a breathing effort reduced to near inexistent levels, and an outstanding level of performance even in very deep waters.

The adjustable Master second-stage regulator makes it possible to modify the inhalation effort thanks to the external metal knob, thus directly affecting inhalation resistance. In practice, screwing the external knob clockwise increases inhalation resistance whereas screwing it anticlockwise decreases inhalation resistance. This regulation system includes two seals designed to protect the water infiltration mechanism. When adequately lubricated during manufacturing/maintenance phase, these seals protect the mechanism thread from the formation of oxide which could stiffen or even block the rotation of the regulation knob.

This way, the knob remains consistently effortless and the subsequent adjustment of the inhalation effort can be achieved with precision and ease as the regulating mechanism thread remains waterproof.

The Galaxy second-stage regulator (fig.8) doesn't allow you to adjust the inhalation effort since it isn't equipped with the regulation mechanism. It does however include all the other features of the adjustable Master version.

The adjustable nozzle is positioned inside the valve compartment so that when the mechanism is opening, the air that comes out of it is directed towards the mouthpiece thanks to the extremely precise and detailed design of the inner walls and casing of the regulator.

In order to ensure the negative pressure isn't too violent for the body - which could potentially suck the diaphragm back in and make the regulator to free-flow - there's a diaphragm balance hole inside the valve unit.

Once the airflow delivered through the injector and directed towards the mouthpiece becomes consistent, it generates negative pressure inside the regulator casing due to the increase in airflow speed. This phenomenon of negative pressure called the "Venturi effect", keeps the diaphragm flat, which in turn significantly reduces the inhalation effort of the diver.

The Venturi effect immediately ceases as soon as the diver stops breathing; the diaphragm then reverts back to its normal position and the lever, actioned by the spring, lifts up and makes the piston touch the nozzle, which interrupts the passage of air.

In order to enhance the Venturi effect, both stages of Cressi-Sub regulators are equipped with an air flow deflector which can be positioned two ways, as indicated by the etched scale on the casing: In the first position, the flow-limitation device placed in the mouthpiece's inlet duct, is actioned and the Venturi effect is stopped and any free-flowing is prevented. In the "+" position however, the Venturi effect is unrestrained and the air flow provided by the regulator to the maximum level subsequently increases.

**DIVE****PRE-DIVE**

fig. 10

**⚠ WARNING:** always remember to keep the flow deflector lever in pre-dive position (-) when the regulator is not in use; if not, any accidental impact or pressure on the manual switch when the regulator isn't positioned inside the mouth, or if it is suddenly removed or the self-breathing apparatus falls into the

*water, can generate even violent high air-consumption free-flowing. The dive position (+) must exclusively be used underwater and only when the regulator is positioned inside the mouth.*

When the diver is breathing, he generates an increase in the pressure inside the regulator casing which opens the oblique elliptical release valve whose larger diameter makes it possible for the air to exit outwards. The exhaust port delivers the air to the sides of the head and prevents the valve being opened because of potential water turbulence, or from being flooded whenever the inner case is not being pressurized.

Another special feature to be found in Cressi-Sub's second-stage regulators comes into play when the regulator is used in cold waters (water temperature of <math><10^{\circ}\text{C}</math> or <math>50^{\circ}\text{F}</math>), a feature engineered with great precision and detailed attention and made possible thanks to the special design of the regulator's valve unit.

Indeed the valve unit's internal flap takes advantage of the temperature increase generated by the diver when he/she exhales, specifically around the nozzle area of the valve, where the risk of freezing is the highest. This patented system greatly enhances the regulator's freeze-resistance.

**⚠ WARNING:** *for diving in cold waters (temperature <math><10^{\circ}\text{C}</math>) Cressi-Sub recommends the use of a tank with a pillar valve with two independent outputs, to which two complete regulators can be connected.*

**⚠ WARNING:** *adequate technical preparation is required before undertaking cold water diving (temperature <math><10^{\circ}\text{C}</math>). Cressi-Sub recommends undertaking this type of diving only after having taken a specific training course with qualified instructors. The use of diving equipment in cold water without a certification or adequate technical preparation is potentially dangerous for the diver's health and wellbeing.*

It is important not to wet the regulator before use (it would then be exposed to an air temperature of potentially well under zero degrees).

Do not use the purge button, particularly when the adjustable Venturi effect knob is in the "dive" position. If possible, keep the regulator in a warm environment before use.

The Cressi-Sub balanced second-stage regulators are connected to one of the 3/8" ports of the first-stage via a new medium-pressure, high-capacity flexible hose in thermoplastic, a material which has excellent mechanical qualities, very high elastic flexibility and remains anti-kink in any situation due to its internal structure. This high-performance material, combined with the regulators' special aesthetically pleasing look and scratch-resistant features make them unique on the current market. Production batches per tube and fittings are labelled according to standard EN 250:2014.

All Cressi-Sub second-stage regulators are downstream, i.e. equipped with an automatic valve opening in the event of first-stage calibration loss or a sudden increase in intermediate pressure.

This means that any excess upstream pressure on the second-stage will never lead to the regulator getting blocked but indeed to spontaneous free-flowing.

The casing of Cressi-Sub second-stage balanced regulators is made of new engineered fabrics with impressive mechanical qualities and characteristics, noise-absorption being one of them.

The new cap (only in the adjustable version) is aesthetically pleasing and designed with special etched Titanium, a material of unsurpassable lightness and corrosion resistance.

The aforementioned cap is computer-designed and the various water passages in the frontal parts of the casing have been thoroughly studied in order to enhance and improve the already impressively high level of performance of Cressi-Sub second-stage regulators.

Cressi-Sub second-stage regulators are in compliance with Direc-

tive 89/686/EEC dated 21/12/1989, checked and certified by the Test Authority No. 474 RINA located in Genoa, tested in compliance with standard EN 250:2014 that establishes the Individual Protection Device (IPD), category III requirements and therefore includes the EC label followed by identification of the certification authority (0474) pursuant to Art. 11A of Directive 89/686/EEC.

## 2.2. - Master / Cromo / Galaxy, dismantling and maintenance

In designing the Master regulator, quick and easy dismantling and maintenance were taken into account, as they are indispensable features for a regulator that is always perfectly serviced, calibrated and efficient.

**⚠ WARNING:** *the dismantling, maintenance and calibration of the 2nd stage regulators should only be carried out by authorized Cressi-Sub centres and the calibration values CANNOT and MUST NOT be changed by the user, to avoid prejudicing the safe operating of the regulator. We cannot be held in any way liable for any intervention carried out by technicians that have not been authorised by Cressi-Sub.*

*You can open and dismantle the second-stage regulator by using the Allen key provided, in order to dismantle the first stage HP and LP plugs, directly accessing its internal mechanics. This extraordinary feature, which is patented and found nowhere else on the market, makes it very easy to open and clean the casing, as well as check the smooth-functioning of each and every component.*

Indeed, the cap and central chamber of the exhaust are mechanically connected thanks to the innovative patented “cam-lock” system that enables an ultra-fast “hinged” opening and closing of the case, which simultaneously blocks the cap and the diaphragm with extreme efficiency and precision.

Opening and closing your regulator has never been as safe and easy!

In keeping with our objective of quick and easy control maintenance and tuning operations, the mechanics of Cressi-Sub second-stage regulators have been designed so as to be instantly removable, without risking altering the level of calibration. Dismantling and replacing worn components whenever maintenance interventions are required can be carried out with the whole mechanics system having been removed from the casing, making it much easier to complete operations.

Logon to our website: [www.cressi.com](http://www.cressi.com) for further important information about our products and equipment.

### 2.3 - XS Compact Pro / XS Compact

The line of XS Compact second stages features revolutionary “downstream” regulators that are lightweight (just 135 gr - the lightest in the Cressi-sub line), with incredibly sleek design.

Designed with meticulous attention to materials, they offer many new characteristics covered by numerous patents, and are manufactured in two specific versions: XS Compact PRO and XS Compact.

The XS Compact PRO is paired only in combination with the MC9 S.C. first stage, since it is designed for specific use in cold water ( $T < 10^{\circ}\text{C}$ ), thanks to the revolutionary technology in the second stage case material, which is manufactured with the new thermo-conductive technopolymer. This material, thanks to its high thermal conductivity, guarantees advanced heat exchange between ambient temperature and the internal temperature in the regulator, preventing icing phenomena in the second stage, which is generally due to the formation of micro-crystals of ice (the result of the natural humidity inside the second stage), following an abrupt drop in the temperature of the air arriving from the first stage which, as it expands during inhalation inside the second stage, in cold water can drop to a few degrees below zero.

**⚠ WARNING:** *In the case of dives in cold water (temperatures lower than  $10^{\circ}\text{C}/50^{\circ}\text{F}$ ), Cressi-sub recommend using a tank supplied with a valve featuring two separate outlet ports, with which two complete regulators can be connected.*

**⚠ WARNING:** *diving in cold water at temperatures lower than  $10^{\circ}\text{C}/50^{\circ}\text{F}$  requires special technical training. Cressi-sub recommends this sort of diving only after having attended a special training course by certified trainers. The use of underwater equipment without a licence or adequate training may be dangerous for the diver's health safety and can even be deadly. The regulator must absolutely not get wet or be exposed to*

*freezing air before use. Do not press the discharge button, particularly when the Venturi effect adjustment lever is on “dive”. If possible, keep the regulator in a warm place before use.*



fig.11 – XS Compact PRO

The XS Compact model however, is sold in combination with different Cressi-sub first stages, always maintaining the same components and the same functions, while varying in each type the color of the caps. All types of XS Compact second stage are designed for use in warm water ( $>10^{\circ}\text{C}/50^{\circ}\text{F}$ ) and guarantee the easiest use to both the beginner and the most experienced diver, offering a complete range of regulators for any type of use.

The case of the XS Compact second stage is made of a new elastic techno-polymer that offers excellent mechanical qualities and that is extremely carefully finished, including 3D photo-incision anti-scratch treatment to protect it from shocks and abrasions to make it exceptionally durable.



fig.12 – XS Compact

When the diver exhales, he causes the pressure inside the case. The cap of the XS Compact second stage features a larger manual airflow button, with a functional return that is better than previous regulators in the Cressi-sub line. It also has a special asymmetrical design in the way the holes are distributed that calibrates the flow of water in order to better optimize the regulator performance.

Second stages in the XS Compact line have been designed to deliver air on demand, that is, only when the diver inhales through the mouthpiece, creating a light depression inside the regulator. This light depression, which is slight enough not to cause breathing effort, works in combination with the external pressure to press against the XS Compact diaphragm, which is properly calibrated to ensure the best useful working surface. In this way the breathing effort is kept at the lowest level while the performance is guaranteed to be the same as that of much larger regulators.

The circular diaphragm, one of the smallest currently on the market, is sucked toward the inside of the case when the diver inhales, pushing the central Teflon coated plate into contact with a lever featuring a revolutionary new patented geometry and variable shape, designed to optimize and drastically reduce friction due to contact between the lever and the diaphragm, by focusing them in a single point on the plate. Friction between lever and plate, as happens in other regulators, is therefore avoided, along with the consequent reduction of the regulator's performance. As it descends, the lever opens the air supply valve, which is also been completely redesigned for maximum manufacturing simplicity compared to previous models.

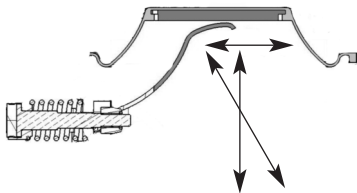

fig. 13

The air exiting the nozzle on the adjustable valve when the mechanism is open is channelled into the injector, which carries it directly to the mouthpiece. Here, the air is accelerated by the Venturi effect, causing a vacuum inside the case. In order to prevent the depression from being too violent and sucking in the diaphragm, which would lead to free flow, the ends of injector and case are designed to optimize and direct a light counter-flow of air towards the diaphragm.

When the air flow inside the injector towards the mouthpiece increases, it is accelerated, as discussed above, by the Venturi effect. The subsequent depression inside the regulator case keeps the diaphragm lowered, and virtually eliminates second stage inhalation effort.

The Venturi effect immediately stops as soon as the diver stops breathing. The diaphragm returns to its normal position, the lever comes up again pushed by its spring, and the nozzle is closed by the piston.

In order to enhance the Venturi effect, XS Compact is equipped with a new ergonomic flow deviator in two modes, which are clearly shown on the regulator: pre-dive and dive (Fig. 14). In the first mode, a flow limiting device placed in the mouthpiece inlet starts operating, and inhibits the Venturi effect, preventing free flow. With the latter on, the Venturi effect is able to work at its best, increasing the air flow released by the regulator to the maximum level.



fig. 14

**⚠ WARNING:** Always remember to set the flow deflector's lever in PRE-DIVE (-) mode when not using the regulator; otherwise, an accidental collision, the regulator falling into water, pressing the manual regulation button without having the mouthpiece in one's mouth, or suddenly taking the regulator out of the mouth might trigger a strong free flow, causing high air consumption.

When the diver exhales, he causes the pressure inside the case to increase and open the discharge valve. This valve, with a completely new design and specially calibrated dimensions, is conical in shape to guarantee a perfect seal for the regulator under all conditions and all positions during use. In addition, the second stage case exhaling section has been designed so as to offer the best performance in combination with the exhaling baffle.

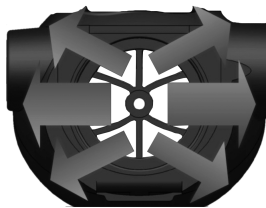

fig. 15

The latter, which can be taken out of the case by means of a special sliding hook, directs all exhaled air away from the diver's face, thanks to a partition placed on its centre which presses the discharge valve in its middle section ensuring that it opens in an extremely controlled way. This way, the regulator's exhaling performance is optimized while also protecting the valve from turbulence in the water that might otherwise open it when the inside of the case is not pressurized, leading to flooding.



fig. 16

The second stage is connected to one of the 3/8" LP ports on the first stage by means of an extremely light and flexible medium-pressure hose, made of a state-of-the-art thermoplastic material that is extremely durable, lightweight, and with excellent flow capacity.

All Cressi-sub XS Compact second stages are downstream, that is, the valve automatically opens in case of calibration loss in the first stage or of a sudden intermediate pressure increase.

This means that any condition of over pressure upstream the second stage leads to automatic free flow, never causing the regulator to get stuck.

The range of Cressi-sub XS Compact regulators is compliant with directive 89/686/EEC of 21/12/1989, and has been tested and certified for use exclusively with:

- warm water (>10°C) relative to model XS Compact/Octopus XS Compact (A>10°C);
- cold water (<4°C) relative to model XS Compact PRO /Octopus Xs Compact Pro (A),

by the 0474 RINA test centre in Genoa, with tests in accordance with standard EN 250:2014, which establishes the requirements for category III Individual Protective Equipment (PPE), and therefore bears the CE Mark followed by the number 0474 identifying the certifying agency, in accordance with Art. 11A of directive 89/686/EEC.



## 2.4 - XS Compact Pro / XS Compact disassembly and servicing

When designing the XS Compact regulator, particular attention was paid to the disassembly and servicing phases, which can always be carried out in utmost safety thanks to its innovative features that make all servicing phases easier, as maintenance is crucial to always have a perfectly serviced, calibrated, and high-performing device.

**⚠ WARNING:** *intermediate pressure must be set only at authorized Cressi-sub centres, while the setting values can NOT and must NOT be modified by the user, in order not to affect the regulator's performance. Cressi-sub decline any responsibility for any intervention carried out by unauthorized personnel.*

**You can find your authorized Cressi-Sub center by asking your dealer, or Cressi Sub S.p.A. itself (email: [info@cressi-sub.it](mailto:info@cressi-sub.it)).**

**NOTE:** *we recommend to have the regulator completely serviced yearly or even oftener in case of intensive use; only original Cressi-sub spare parts are to be used.*

The unique bayonet mount lock system of the cap allows the case to be easily opened and closed, and at the same time it locks cap and seal in all safety and precision; there is no mechanic coupling thread as in most other regulators on the market, that may cause problems affecting their performances. Moreover, a specially sized mechanic insert guarantees the regulator to be safely and precisely locked.



fig. 17

Opening and locking a common circular seal case regulator has never been so easy as well as so safe. Every operation of checking, servicing and setting of the second stage is made easier and faster.

To reach this goal, we designed a revolutionary patented cap on the device side, which avoids using a threaded coupling. The valve as well can be serviced and set in an extremely easy way guaranteeing the second stage utmost performance and perfect tightness.

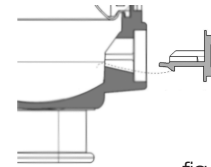

fig. 18

**⚠ WARNING:** *the second stage can be opened, disassembled and set only and exclusively at authorized Cressi-sub centres; the setting values CANNOT and MUST NOT be varied by the user, so as not to affect the device performances. We decline any responsibility for any operation carried out by unauthorized personnel.*

**NOTE:** *we recommend to have the regulator completely serviced yearly or even oftener in case of intensive use; only original Cressi-sub spare parts are to be used.*

Visit our site [www.cressi.com](http://www.cressi.com): you will find more information about our equipment.

## 2.5 - XS2

Second stage supplies air “on demand”, that is only when the diver inhales from the mouthpiece, causing a slight vacuum inside the regulator, which must be very slight in order not to make breathing difficult. Such vacuum acts on the diaphragm, which is sucked in towards the inside, causing the central plate to touch the lever. The latter opens the air supply valve.



fig. 19

The valve of XS2 is composed of a renovated modular poppet in plastic and chromium-plated brass, which is interchangeable with previous models of XS range: on one side, it is connected to the lever, on the other side, it houses a newly designed thicker rubber pad, closing the new adjustable nozzle, through which the air flows at a pressure by 10 bar (145 psi) higher than the environmental.

The air contained in the nozzle pushes the pad, which is contracted by the poppet's spring.

Therefore, the renovated poppet “floats” between the push of inflowing air and the spring which, having a slightly higher strength, closes the nozzle perfectly.

The adjustable nozzle is placed inside the valve seat. The outflow air, when the mechanism is open, is directed through the injector and directly into the mouthpiece.

When the air flow inside the injector towards the mouthpiece increases, it generates a vacuum inside the regulator's case, due to its acceleration. This vacuum, called Venturi effect flattens the diaphragm, remarkably reducing the diver's breathing effort. The Venturi effect immediately stops as soon as the diver stops breathing. The diaphragm returns to its normal position, the lever comes up again pushed by its spring, and the nozzle is closed by the piston.

To optimize the Venturi effect, XS2 CE is supplied with a flow deflector with two operating modes, clearly shown by the scale on the regulator housing:

pre-dive “-“ and dive “+” (picture 20). In first mode, a flow limiting device placed in the mouthpiece inlet starts operating and inhibits the Venturi effect, preventing free flow. In “+” mode, the Venturi effect works at its best, increasing the air flow supplied to the regulator to the maximum level.

**⚠ WARNING:** Always remember to set the flow deflector's lever in pre-dive (-) mode when not using the regulator; otherwise, an accidental collision, the regulator falling into water, pressing the manual regulation button without having the mouthpiece in one's mouth, or suddenly taking the regulator out of the mouth might operate a strong free flow, causing high air consumption.  
The dive (+) mode can only be used while diving and only when the regulator is inside the mouth.

When the diver exhales, the pressure inside the regulator's case increases, opening the exhaust valve. This has been fully redesigned and shows a larger diameter as well as a specially angled conical shape, allowing air to flow outside. The exhaust tee directs the air towards the head's sides and protects the valve from water turbulences which might lift it, when the inside is depressurized, and flood it.

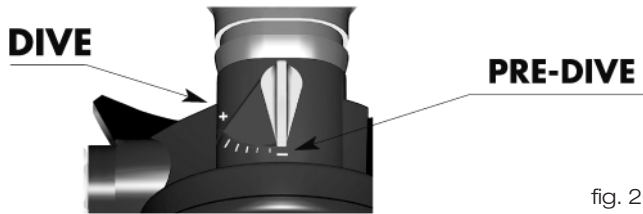

fig. 20

The 2nd stage is connected to one of the first stage's 3/8" ports by means of a flexible medium pressure and high capacity hose.

All Cressi-sub second stages are downstream, that is the valve automatically opens in case of calibration loss of first stage or of a sudden intermediate pressure increase.

This means that any condition of over pressure upstream the second stage leads to automatic free flow, never causing the regulator to get stuck.

XS2 features a case in new techno-polymers with excellent mechanic qualities and an attractive aggressive look. The maintenance is outstandingly easy and affordable, still easier on this model thanks to a side tap, with its own O-Ring, for the valve precise setting.

**⚠ WARNING:** *intermediate pressure must be set only at authorized Cressi-sub centres, while the setting values can NOT and must NOT be modified by the user, in order not to affect the regulator's performance. Cressi-sub decline any responsibility for any intervention carried out by unauthorized personnel.*

**You can find your authorized Cressi-Sub center by asking your dealer, or Cressi Sub S.p.A. itself (email: [info@cressi-sub.it](mailto:info@cressi-sub.it)).**

Inner components are in chromium-plated brass, stainless steel and acetyl resins; springs are in stainless steel, diaphragms in silicone, O-rings in NBR and the mouthpiece in comfortable hypoallergenic silicone.

## 2.6 - Ellipse Octopus



fig. 21

The Ellipse second stage is a highly innovative, elliptical shaped downstream regulator, featuring a weight as low as 158 g and futuristic design.

The Ellipse has been designed to deliver air "on demand", that is to say, only when the scuba diver inhales through the mouthpiece and in doing so creates a slight negative pressure inside the regulator. This negative pressure, which must be minimal in order not to cause respiratory fatigue, acts on the elliptical shaped, variable section diaphragm of the Ellipse, which has been designed to obtain an increase in useful surface area and maintain the inhalation effort down to the lowest possible level. This ensures performances on a par with those typically associated with much bigger regulators.

All regulators have the same mechanism and functional peculiarities, the same case in a new elastic techno-polymer with excellent mechanic qualities which reduce noises dramatically; therefore, from now on we will name the products generally "Ellipse".

Ellipse was designed to supply air “on demand”, that is only when the diver inhales from the mouthpiece, causing a slight vacuum inside the regulator, which must be very slight in order not to make breathing difficult. Such vacuum acts on the special variable-section elliptical diaphragm, which has been designed to get a larger working surface and to keep the breathing effort as low as possible, guaranteeing same performance as larger sized regulators’.

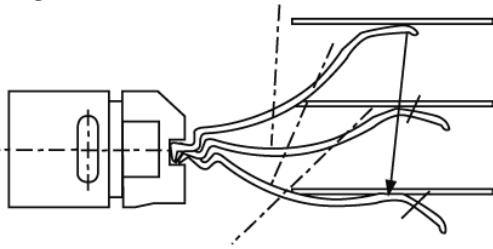

fig. 22

The diaphragm, sucked in towards the inside, causes the central plate to touch the lever, which has a new revolutionary shape, designed to optimize and reduce dramatically the friction between lever and diaphragm, concentrating it onto a single spot of the plate. The friction between lever and plate, as happens in other regulators, is therefore avoided, along with the consequent reduction of the regulator’ s performance. The lever’ s task is assisted by its special patented profile and by a new patented system of swinging motion of the piston.

When touched, the lever opens the air supply valve, which has been completely redesigned. The air flowing out of the valve adjustable nozzle when the mechanism is open is led into the injector leading it directly to the mouthpiece. Here, the air is accelerated by the Venturi effect, causing a vacuum inside the case. In order not to make it too sudden, that might “suck in” the diaphragm and cause a free continuous intense air flow, the end of the injector is shaped as to direct a small opposite air flow towards the diaphragm.

A “valve-guiding” bush made of a special thermoplastic rubber, placed inside the valve, performs the following two functions: guides the spindle motion, reducing friction between the mechanic elements each time the valve opens, and protects the regulator in case the valve starts freezing at its most crucial point. In this way, all the air required by the diver is only fed inside the injector, thus avoiding any air loss in the connection of spindle and valve-housing. Such loss would interfere with the diaphragm bending, therefore causing the breathing effort to increase.

When the air flow inside the injector towards the mouthpiece increases, it is accelerated, as seen before, by the Venturi effect. The consequent vacuum inside the regulator’ s case flattens the diaphragm, virtually reducing the diver’ s breathing effort to zero. The Venturi effect immediately stops as soon as the diver stops breathing. The diaphragm returns to its normal position, the lever comes up again pushed by its spring, and the nozzle is closed by the piston.

To optimize the Venturi effect, Ellipse is supplied with a new ergonomic flow deflector with two operating modes, clearly shown by the scale on the regulator housing: pre-dive “-“ and dive “+“ (picture 23). In first mode, a flow limiting device placed in the mouthpiece inlet starts operating and inhibits the Venturi effect, preventing free flow. In “+“ mode, the Venturi effect works at its best, increasing the air flow supplied to the regulator to the maximum level.

**⚠ WARNING:** Always remember to set the flow deflector’ s lever in pre-dive (-) mode when not using the regulator; otherwise, an accidental collision, the regulator falling into water, pressing the manual regulation button without having the mouthpiece in one’ s mouth, or suddenly taking the regulator out of the mouth might operate a strong free flow, causing high air consumption.  
The dive (+) mode can only be used while diving and only when the regulator is inside the mouth.

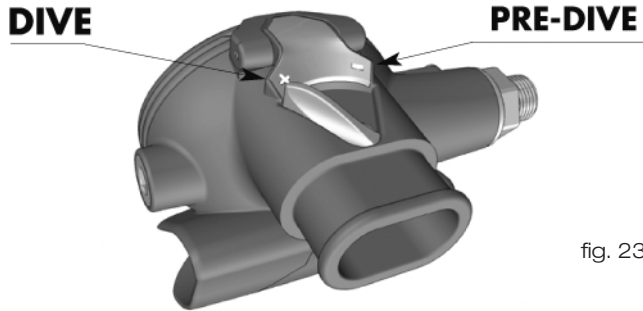

fig. 23

When the diver exhales, the pressure inside the regulator's case increases, opening the exhaust valve. This has been fully redesigned and shows a larger diameter as well as a specially angled conical shape, making the regulator perfectly watertight in any condition of use. The newly designed exhaust tee comes directly out of the regulator's case, thus creating an extremely compact assembly with outstanding design. The air is led towards the head's sides, while the particular shape of the exhaust valve housing protects the valve itself from water turbulences which might lift it, when the inside is depressurized, and flood it.

Moreover, a special bulkhead on the exhaust tee centre line presses the exhaust valve on its middle section, ensuring its balanced opening.

The 2nd stage is connected to one of the first stage's 3/8" ports by means of a flexible medium pressure and high capacity hose.

Ellipse Cressi-sub is a downstream regulator, that is the valve automatically opens in case of calibration loss of first stage or of a sudden intermediate pressure increase.

The Cressi-sub Ellipse second stage conforms to directive 89/686/EEC of 21/12/1989, having been tested and certified by

Notified Body number 0474, RINA, with registered office in Genoa, with a test conducted pursuant to standard EN 250:2014 which specifies the requirements for class III personal protection equipment (PPE), and therefore it carries the CE mark followed by the ID data of the notified body (0474) pursuant to Art. 11 of directive 89/686/EEC.

## 2.7 - Ellipse, disassembly and maintenance

By designing Ellipse regulators, great attention has been paid as to the simplicity and speed of disassembly and maintenance, unavoidable qualities for an always perfectly serviced, set and performing regulator.

**⚠ WARNING:** *intermediate pressure must be set only at authorized Cressi-sub centres, while the setting values can NOT and must NOT be modified by the user, in order not to affect the regulator's performance. Cressi-sub decline any responsibility for any intervention carried out by unauthorized personnel.*

**You can find your authorized Cressi-Sub center by asking your dealer, or Cressi Sub S.p.A. itself (email: [info@cressi-sub.it](mailto:info@cressi-sub.it)).**

Using the included Allen key to unscrew the HP and LP caps of the first stage, you can open and disassemble the second stage, directly getting to its inner mechanism. This unique and patent edfeature allows to open the case in an extremely easy and quick way, to clean it and check the perfect working of all its components.

A new patented cam-lock system allows to open and close the case very quickly, at the same while blocking cap and diaphragm perfectly and precisely.

A regulator has never been opened and closed in such a simple and safe way!

The whole mechanism of second stage has been designed to ensure easy and quick servicing and can therefore be taken out of the case, without changing its calibration. Disassembling and replacement of worn parts, on occasions of periodical servicing, may be carried out holding the whole mechanism in one hand.

Visit our web-site [www.cressi.com](http://www.cressi.com), where you can find further information relating to your equipment.



*Direction for use regulators*

## **2.8 - Performance Second Stages**

## 2.8 - Performance

<b>Master</b>	
Working pressure	0÷232 bar (INT); 0÷300 bar (DIN)
Calibration pressure (with 200 bar supply)	10 bar (T10 S.C. - T10 S.C. Cromo)
Average inhalation effort (*)	3 mbar
Average exhalation effort (*)	7 mbar
Average work of breathing (*)	0,6 J/l
Air Supply	2500 l/min.
Weight without hose	207 gr

(\*) Values measured in compliance with standard EN 250:2014.

<b>Galaxy</b>	
Working pressure	0÷232 bar (INT); 0÷300 bar (DIN)
Calibration pressure (with 200 bar supply)	10 bar (T10 S.C.)
Average inhalation effort (*)	3 mbar
Average exhalation effort (*)	7 mbar
Average work of breathing (*)	0,6 J/l
Air Supply	2500 l/min.
Weight without hose	182 gr

(\*) Values measured in compliance with standard EN 250:2014.

<b>XS Compact Pro / XS Compact</b>	
Working pressure	0÷232 bar (INT); 0÷300 bar (DIN)
Calibration pressure (200 bar feeding)	10 bar (MC9 - MC5 - AC2)
Average inhalation effort (*)	6 mbar
Average exhalation effort (*)	10 mbar
Average breathing effort (*)	1,1 J/l
Air supply	1600 l/min.
Weight without hose	135 gr

(\*) Values measured in compliance with EN 250:2014 standard.



## 2.8 - Performance

<b>XS2</b>	
Working pressure	INT: 0÷232 bar (INT); 0÷300 bar (DIN)
Calibration pressure (200 bar feeding)	10 bar (AC2)
Average inhalation effort (*)	10 mbar
Average exhalation effort (*)	13 mbar
Average breathing effort (*)	1,4 J/l
Air supply	1050 l/min.
Weight without hose	200 gr

(\*) Values measured in compliance with EN 250:2014 standard.

<b>Ellipse Octopus</b>	
Working pressure	INT: 0÷232 bar; DIN: 0÷300 bar
Calibration pressure (200 bar feeding)	10 bar
Average inhalation effort (*)	4 mbar
Average exhalation effort (*)	11 mbar
Average breathing effort (*)	0,95 J/l
Air supply	1800 l/min.
Weight without hose	158 gr

(\*) Values measured in compliance with EN 250:2014 standard.



*Direction for use regulators*

### **3 - Use and Maintenance**

### 3.1 – Use of the regulator and risk assessment

The regulator should be used only by divers who have attended and completed successfully a special technical training course, obtaining an underwater licence.

Nonetheless, before any use all environmental conditions should be assessed, as well as the diver's psychophysical state: if just one aspect is risky, diving must be avoided.

Among possibly risky environmental conditions, are the sea state, the presence of currents, particularly low water temperature, reduced visibility.

Among psycho-physical conditions, please consider imperfect health, emotional or physical stress, lack of training, tiredness, bad digestion.

Do not forget that after a long time without diving, you are particularly at risk, since you might have lost part or all of the skills learnt at the training course.

Cressi-sub regulators' top quality materials and anti-corrosion treatments allow their use in full safety.

Please remember that the open circuit air regulators are designed and tested for use up to a depth of 50 m/164 ft, in accordance with EN 250:2014 standard, but recreational diving should not be deeper than 40 m/131 ft., without any type of underwater work.

### 3.2 – Checks before use

Before using your Cressi-sub regulator, we recommend to carry out some easy though very important and unavoidable checks, in order to avoid any kind of problem.

Check, for example, if the hoses are perfectly connected with the first stage: in case they can be manually disconnected, you should screw them down with a key, before loading the regulator. Moreover, check the hoses do not look worn in any way and are not cut or damaged at all.

In the same way, check the first and second stages for any damage: check, for example, the second stage's mouthpiece for cuts or scratches and connect it perfectly with the first stage by means of a lock band.

Before opening the tank's valve, check the underwater pressure gauge reports zero pressure.

The tanks' pressure must be checked by means of the special underwater gauge or of a computer with such function: after opening the tank's valve, the gauge must show the tank's correct working pressure.

**⚠ WARNING:** *the regulator must be checked out of the water, by depressing the manual supply button repeatedly, in order to check the regular air supply; then, wear your mouth-piece and make some deep inhalations and exhalations, in order to check its perfect working (not for use in cold water < 10°C/< 50°F).*

*The same must be done on the water surface, before plunging, wearing your mouthpiece and turning you head so that the regulator is completely under water: inhale and exhale deeply, in order to check its perfect working, in both phases of air supply and discharge.*

***This test must be done also with the reserve regulator, be it an independent regulator or an octopus (two second stages connected with an only first stage).***

Should you have also an "octopus" (two second stages connected with an only first stage) you must test the reserve second stage as well.

A last acoustic test might discover and/or point out possible losses from connections and hoses or a free air flow from the second stage: these are all anomalous situations requiring immediate servicing or replacement of damaged components.

Should these anomalies be revealed, DO NOT dive and get to an authorized Cressi-sub centre to ask for all necessary servicing, before using your equipment again.

**⚠ WARNING:** After assembling and checking it, the regulator must be laid down horizontally, in order to prevent any accidental fall from causing damage to its components or injury to people.

### 3.3 - Mounting the regulator to the tank

Before assembling, check the tank has been filled with exclusively compressed air working pressure, using a suitable compressor, which supplies breathable air in compliance with EN 12021 standards.

We remind that only test certified tanks can be filled within the lapse of time reported by the certificate itself.

**⚠ WARNING:** check the perfect state of the valves watertight O-rings. They must not show any cut, scratch or other damage; they must be replaced anyway at regular intervals of time, even if being in perfect state, since they are subjected to the tanks air high pressure and to atmospheric agents as well. We recommend to use only original Cressi-sub spare parts.

For yoke connected first stages, use following procedure: slightly unload the tank, opening its valve a little, in order to free its end from any residual water. After unscrewing the yoke's lock knob, take the protection tap out of its seat and place the first stage on the air exit valve, checking the second stage is positioned correctly. Now, screw the yoke's knob to lock the first stage on the valve.

You do not need to tighten the knob too much.

Open the tank valve, turning it anticlockwise, keeping pressed the manual supply button of the second stage for a while (this is to be avoided in cold water).

**⚠ WARNING:** diving in cold water at temperature lower than 10°C/50 °F requires a special technical training. Cressi-sub recommend such diving only after attending a special training course by certified trainers. Using underwater equipment in cold water without adequate training may be dangerous for the diver's health and life.

*The regulator must absolutely not get wet and exposed to freezing air before use. Do not press the discharge button, particularly when the Venturi effect adjustment lever is on "dive". If possible, keep the regulator in a warm place before use.*

We highly recommend, as a rule, to open the tank valve slowly, so that the regulator gets filled gradually. If the regulator gets pressurized too suddenly, in fact, it creates an adiabatic compression of the breathable gas inside the 1st stage, that might cause the equipment to work imperfectly.

As soon as you hear air flowing out of the second stage, stop pressing the manual supply button and open the valve fully. It is advisable to turn the valve clockwise for a quarter, in order to avoid damaging the poppet thread.

For DIN connection first stages, assembling does not differ a lot from that described above.

You just have to screw the connection directly onto the valve, without tightening too much.

In case a second independent regulator is used, connect it to the additional valve outlet following the above instructions.

**⚠ WARNING:** Do not turn the first stage connected with the tank when the system is pressurized; do not use the first stage connected with the valve as a handle to carry the equipment: it might damage the regulators, its O-rings and the valves.

**⚠ WARNING:** if the hoses are not positioned correctly, do not try to arrange them well when the regulator is pressurized. Close the tank, depressurize and, only then, position the hoses correctly.

**⚠ WARNING:** After assembling and checking it, the regulator must be laid down horizontally, in order to prevent any accidental fall from causing damage to its components or injury to people.

### 3.4 - Use of the regulator in cold water

If your regulator is certified to be used in **cold water** (temperatures < 10° C/50°F), Cressi sub recommend to follow carefully the following advices in order to reduce the risk of freezing:

1. Protect the regulator from any accidental water in flow into the first and second stages;
2. Protect the equipment from cold before diving, keeping it in a warm dry place;
3. Avoid breathing through the regulator or pressing the discharge button in freezing air before diving;
4. Avoid taking the mouthpiece out of your mouth when out of water and while getting into water, in order not to let cold water seep into the second stage;
5. As far as possible, avoid consuming a great amount of water by diving (inflating gav, inflating surfacing or signalling buoy, sharing air with another diver etc.);
6. Check the air contained in the tank satisfies the requisites prescribed by EN 12021 standard and is free from excessive humidity.

**⚠ WARNING:** *In case of dives in cold water (temperature less than 10°C/50° F), Cressi-sub recommend to use a tank supplied with a valve featuring two separate outlet ports, with which two complete regulators are to be connected.*

**⚠ WARNING:** *diving in cold water at temperature lower than 10°C/50 °F requires a special technical training. Cressi-sub recommend such diving only after attending a special training course by certified trainers. Using underwater equipment in cold water without adequate training may be dangerous for the diver' s health and life.  
The regulator must absolutely not get wet and exposed to freezing air before use. Do not press the discharge button, particularly when the Venturi effect adjustment lever is on "dive". If possible, keep the regulator in a warm place before use.*

**⚠ WARNING:** *if the components of the SCUBA equipment are configured and used simultaneously by multiple divers, the equipment may not be used at depths of greater than 30 meters, or at water temperatures below 10 °C.*

### 3.5 - Care and maintenance of the equipment

#### 3.5.1. - Caring for the equipment

After use, close the tank valve turning it clockwise fully. Press the second stage manual supply button in order to let out all water from hoses and connections.

Disassemble the first stage unscrewing the knob anticlockwise.

Protect the sintered filter with your finger while blowing off all water and impurities from the protecting cap. Place now the latter on the first stage air inlet port and lock it with the knob, taking-care the cap' s O-ring is in place as well.

After every use, we recommend to rinse the regulator in fresh water while still pressurized: in this way, it is possible to wash the whole second stage, preventing any impurity from reaching theregulator, that might compromise its watertight capacity. Rinse the first stage letting water flow also through the second stage' smouth piece and the exhaust tees, in order to take off any impurity.

When rinsing the depressurized regulator, rinse the first stage letting water flow also through the second stage' s mouthpiece and the exhaust tees, in order to take off any impurity: be sure not to press the manual supply button, in order to prevent water from flowing into the hoses and inside the first stage.

Let the regulator dry in a cool aired place, placing the hoses in such way as not to form acute angle folds.

Cressi-sub regulators must be serviced once a year and oftener in case of particularly intensive use.

**⚠ WARNING:** *intermediate pressure must be set only at authorized Cressi-sub centres, while the setting values can NOT and must NOT be modified by the user, in order not to affect the regulator' s performance. Cressi-sub decline any responsibility for any intervention carried out by unauthorized personnel.*

**You can find your authorized Cressi-Sub center by asking your dealer, or Cressi Sub S.p.A. itself (email: [info@cressi-sub.it](mailto:info@cressi-sub.it)).**

In case a regulator is used by more than a divers (diving centres, clubs etc), we recommend to disinfect it by placing it for 2/3 minutes in a 2% Stereamine G water solution or other similar pharmaceutical products.

All CRESSI-SUB regulators comply with 89/686/EEC directive of 21/12/1989, checked and certified by N. 0474 RINA – Genoa, with tests in accordance with EN 250:2014 standard, which provides the requisites of III class Individual Safety Devices: the device therefore is EC branded and reports the certifying institute indication (0474), as prescribed by Art. 11A of 89/686/EEC directive.

### 3.5.2. - Equipment maintenance

Cressi-sub recommend the regulator is serviced at least once a year, notwithstanding the number of dives carried out. Servicing might also be more frequent according to intensive use.

In both cases, please remember that both the diver's safety and the regulator's performance depend first of all on a correct servicing.

This must include an examination of the equipment, a full overhaul, and repair (where needed), by an authorized Cressi-Sub center and must be documented in the Service Record provided by Cressi-Sub and found in this manual in section 3.7.

In order to ensure the best results, when maintenance operation are performed, we recommend using all the spare parts provided by Cressi-Sub in every procedure.

Maintenance (or repair) operations for the equipment must exclusively use original Cressi-Sub spare parts.

Users must never perform maintenance themselves; all maintenance must be performed by an authorized Cressi-Sub center.

If improper maintenance is performed on the equipment, per-

formed by someone other than authorized Cressi-Sub personnel, or used for purposes other than those specifically intended, responsibility for proper and safe operations fall to the owner/user.

**⚠ WARNING:** *the regulators must be serviced exclusively at an authorized Cressi-sub centre, using only original spare parts. Interventions carried out by untrained personnel may cause high risks to the diver's health and life. Cressi-sub decline any responsibility for any servicing or setting of the regulators carried out by unauthorized and uncertified personnel.*

**NOTE:** **You can find your authorized Cressi-Sub center by asking your dealer, or Cressi Sub S.p.A. itself by sending an e-mail to: [info@cressi-sub.it](mailto:info@cressi-sub.it)**

### 3.6 - Use with Nitrox mixtures

**⚠ WARNING:** *Cressi-sub discourages Nitrox dives without proper training. Nitrox dives will expose the diver to different risks than those of air dives, including serious physical damage and, in extreme cases, even death.*

**⚠ WARNING:** *as regards EEC countries, Cressi-sub regulators and octopus devices can only be used with atmospheric compressed air that meets the requirements of the EN 12021 standard. Do not use these devices with other gas mixtures or with enriched air (corresponding to O<sub>2</sub> > 22%). Failure to comply with this warning can lead to operating defects, and also cause the equipment to wear prematurely, or even lead to possible explosions, which can cause serious damage.*

**⚠ WARNING:** *as regards Extra-EEC countries, Cressi-sub regulators and octopus are compatible with the use of open-circuit SCUBA equipment that uses compressed air or enriched air mixtures (Nitrox) with oxygen percentages no greater than 40%. Failure to observe this warning may result in serious or mortal injury to the user caused by fires, explosions, or deterioration or breakage of the equipment.*

All Cressi-sub regulators are supplied with NBR O-rings and all inner components are greased with silicone, that guarantee the best lubrication and protection from salted and corrosive sea environment.

As proved by tests carried out by NASA (NASA DOCUMENT TR-900-001), using silicone lubricants is excellent for equipment using Nitrox hyper-oxygenated mixtures with oxygen percentage up to 40%.

The most recent European standards EN13949 and EN144/3 prescribe all equipment using mixtures containing more than 22% oxygen to be certified also with a pure oxygen working test, which is difficult to get through using silicone lubricants.

Cressi-sub regulators are therefore EC certified only for use with air and mixtures containing less than 22% oxygen and must not be used, in EEC countries, with hyper-oxygenated mixtures.

3.7 - Maintenance/recording of procedures (Service Record)

MODEL	SERIAL NUMBER	DATE	DEALER NAME	TECHNICIAN'S NAME	NOTES ON PROCEDURES (Date of the next scheduled maintenance)	SIGNATURE



### 3.8 - Cressi-sub Certified Combinations.

Note: Cressi sub regulators can only be used with SCUBA component assemblies according to the combinations certified for conformity to directive 89/686/ECC and standard EN 250:2014.

	FIRST STAGES						
	T10 S.C.	T10 CROMO	T10 S.C. CROMO	MC9 S.C.	MC9	MC5	AC2
<b>Galaxy</b>		● A<10°					
<b>Master</b>	● A<10°						
<b>Master (Cromo)</b>			● A<10°				
<b>XS Compact Pro</b>				● A<10°			
<b>XS Compact</b>					● A>10°	● A>10°	● A>10°
<b>XS2</b>							● A>10°
<b>Octopus XS Compact Pro</b>	A<10°	A>10°	A<10°	A<10°			
<b>Octopus XS Compact</b>					A>10°	A>10°	A>10°
<b>Ellipse Octopus</b>					A>10°	A>10°	A>10°
<b>Octopus XS2</b>					A>10°	A>10°	A>10°

**SECOND STAGES**

# **CRESSI**

SINCE 1946

## *Regulators Chart*

**Primi Stadi**  
**First Stages**  
**Premiers Etages**  
**Erste Stufen**  
**Primeras Etapas**  
**ВТОРЫЕ СТУПЕНИ**  
**一级头**

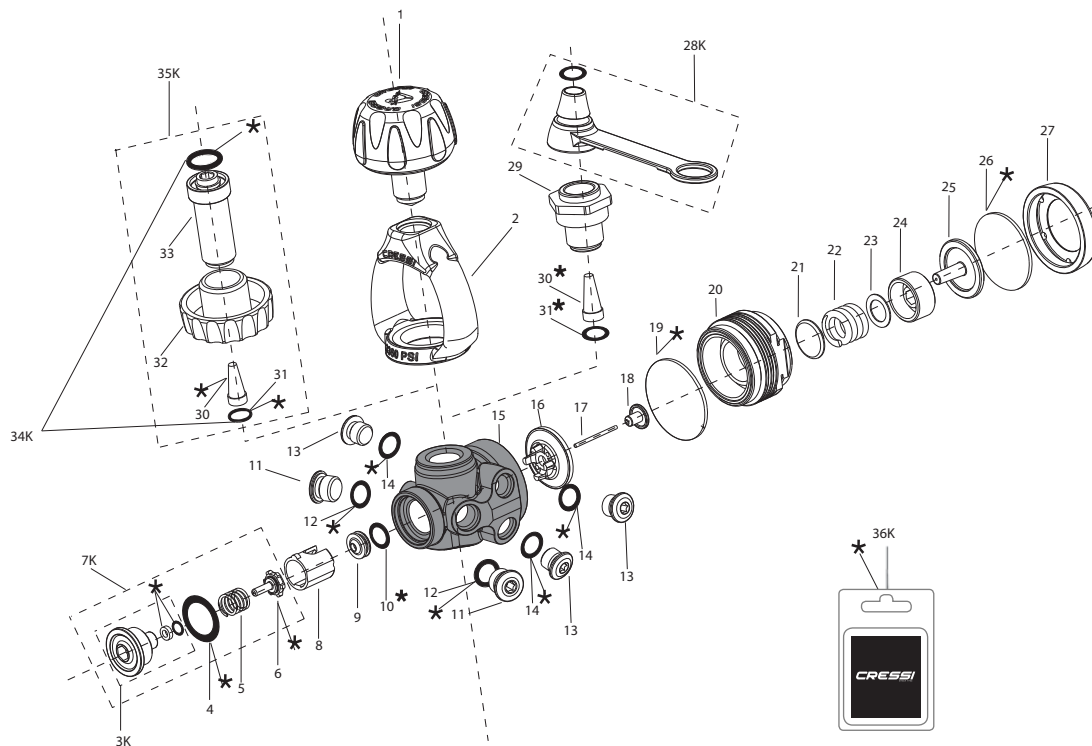

- |     |                 |
|-----|-----------------|
| 1   | HZ730027        |
| 2   | HZ770080        |
| 3k  | HZ830081 *      |
| 4   | HZ830082 *      |
| 5   | HZ800086        |
| 6   | HZ800085 *      |
| 7k  | HZ830083        |
| 8   | HZ830084        |
| 9   | HZ800042        |
| 10  | HZ800043 *      |
| 11  | HZ730127        |
| 12  | HZ730132 *      |
| 13  | HZ730106        |
| 14  | HZ730108 *      |
| 15  | HZ830085        |
| 15  | HZ830089 Chrome |
| 16  | HZ830086        |
| 17  | HZ800038        |
| 18  | HZ830088        |
| 19  | HZ800082 *      |
| 20  | HZ830080        |
| 21  | HZ800081        |
| 22  | HZ800080        |
| 23  | HZ800064        |
| 24  | HZ800065        |
| 25  | HZ800010        |
| 26  | HZ800011 *      |
| 27  | HZ800079        |
| 28k | HZ800090        |
| 29  | HZ830090        |
| 30  | HZ830091 *      |
| 31  | HZ730108 *      |
| 32  | HZ830092        |
| 33  | HZ830093        |
| 34k | HZ830094        |
| 35k | HZ830035        |
| 36k | HZ800045 *      |

(kit revisione/maintenance kit)

1° Stadio Membrana Bilanciata T10 S.C. € / Balanced Diaphragm 1<sup>st</sup> Stage T10 S.C. €

Ed./Issue

02/15

T10 SC-SCCr/A

N° Tav./Rev.

HZXXXXXX\* Contenuto nel kit revisione e non disponibile singolarmente. / Only available in maintenance kit; not available individually. HZXXXXXX Non disponibile / Not available.

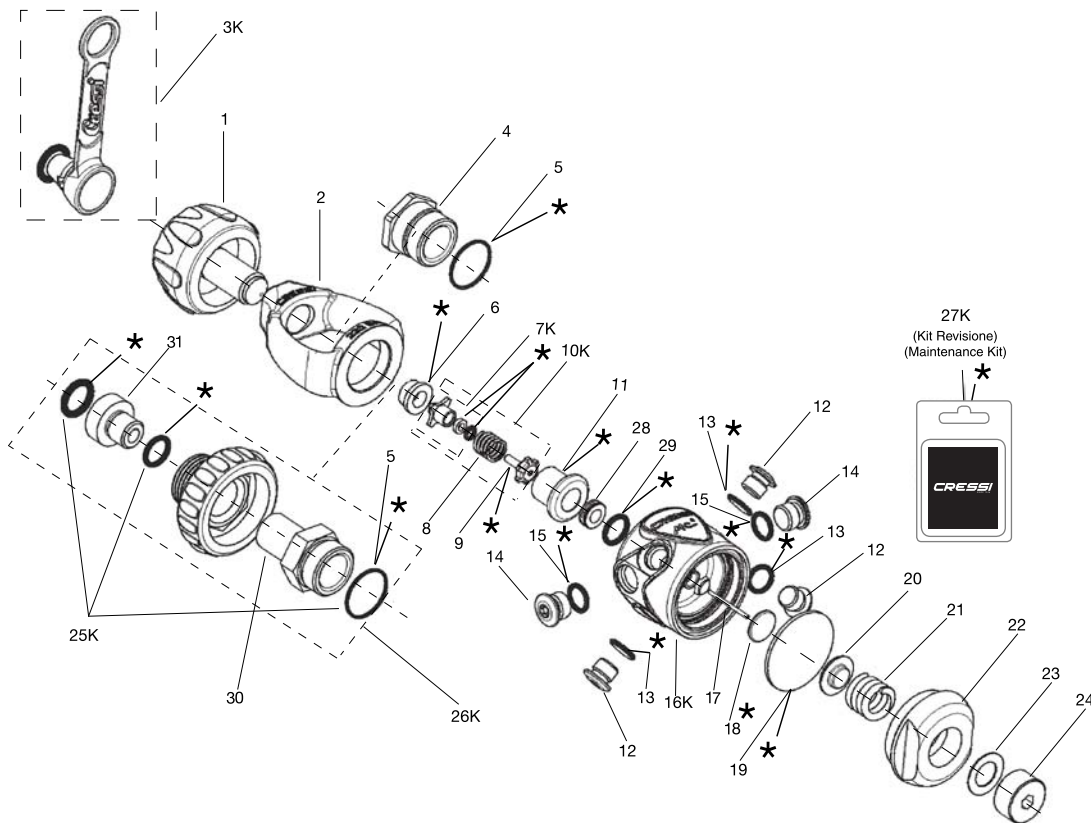

- |     |                                 |
|-----|---------------------------------|
| 1   | HZ730027                        |
| 2   | HZ770080                        |
| 3k  | HZ800090                        |
| 4   | HZ800054                        |
| 5   | HZ800055*                       |
| 6   | HZ800056*                       |
| 7k  | HZ800057*                       |
| 8   | HZ800086                        |
| 9   | HZ800085*                       |
| 10k | HZ800058                        |
| 11  | HZ800059*                       |
| 12  | HZ730106                        |
| 13  | HZ730108*                       |
| 14  | HZ730127                        |
| 15  | HZ730132*                       |
| 16k | HZ800040                        |
| 17  | HZ800041                        |
| 18  | HZ800062*                       |
| 19  | HZ800082*                       |
| 20  | HZ800081                        |
| 21  | HZ800080                        |
| 22  | HZ800063                        |
| 23  | HZ800064                        |
| 24  | HZ800065                        |
| 25k | HZ800066*                       |
|     | (kit CR DIN)                    |
| 26k | HZ800067                        |
| 27k | HZ800047*                       |
|     | (kit revisione/maintenance kit) |
| 28  | HZ800042                        |
| 29  | HZ800043*                       |
| 30  | HZ800049                        |
| 31  | HZ800046                        |

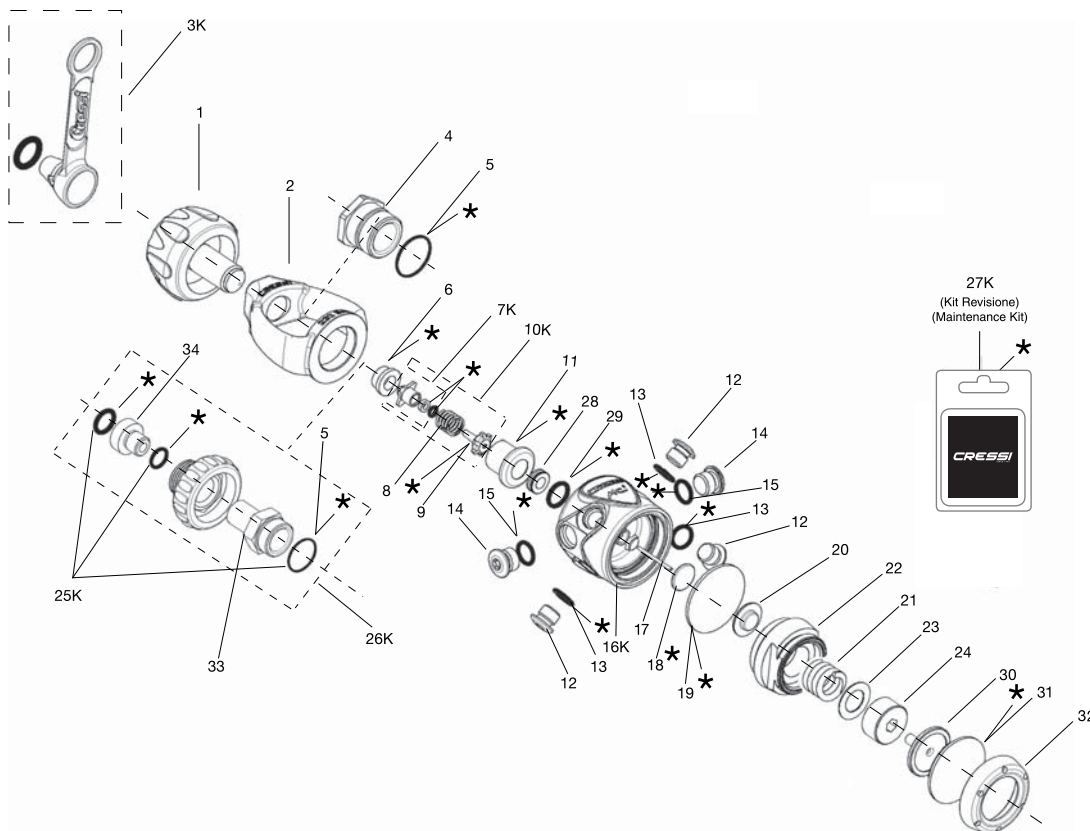

- |     |                                 |
|-----|---------------------------------|
| 1   | HZ730027                        |
| 2   | HZ770080                        |
| 3k  | HZ800090                        |
| 4   | HZ800054                        |
| 5   | HZ800055*                       |
| 6   | HZ800056*                       |
| 7k  | HZ800057*                       |
| 8   | HZ800086                        |
| 9   | HZ800085*                       |
| 10k | HZ800058                        |
| 11  | HZ800059*                       |
| 12  | HZ730106                        |
| 13  | HZ730108*                       |
| 14  | HZ730127                        |
| 15  | HZ730132*                       |
| 16k | HZ800040                        |
| 17  | HZ800038                        |
| 18  | HZ800062*                       |
| 19  | HZ800082*                       |
| 20  | HZ800081                        |
| 21  | HZ800080                        |
| 22  | HZ800039                        |
| 23  | HZ800064                        |
| 24  | HZ800065                        |
| 25k | HZ800066*                       |
|     | (kit OR DIN)                    |
| 26k | HZ800067                        |
| 27k | HZ800047*                       |
|     | (kit revisione/maintenance kit) |
| 28  | HZ800042                        |
| 29  | HZ800043*                       |
| 30  | HZ800010                        |
| 31  | HZ800011*                       |
| 32  | HZ800012                        |
| 33  | HZ800049                        |
| 34  | HZ800046                        |

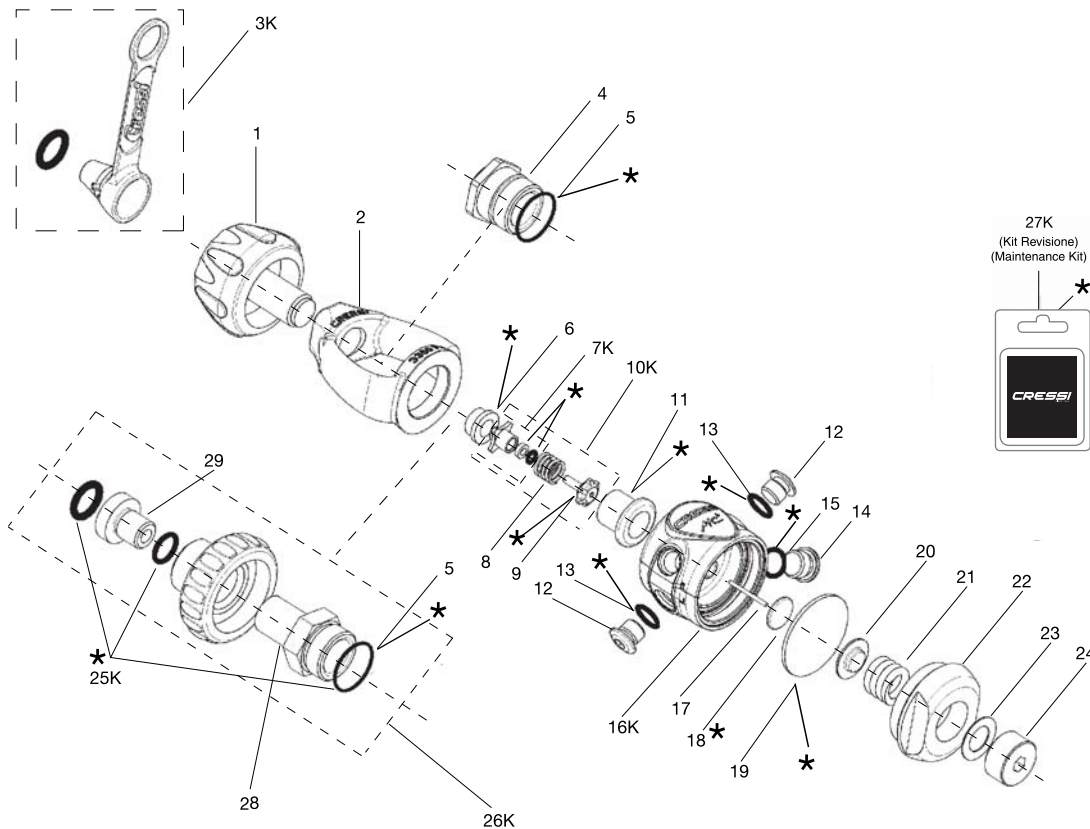

- |     |  |
|-----|--|
| 1   | HZ730027                               |
| 2   | HZ770080                               |
| 3k  | HZ800090                               |
| 4   | HZ800054                               |
| 5   | HZ800055*                              |
| 6   | HZ800056*                              |
| 7k  | HZ800057*                              |
| 8   | HZ800086                               |
| 9   | HZ800085*                              |
| 10k | HZ800058                               |
| 11  | HZ800059*                              |
| 12  | HZ730106                               |
| 13  | HZ730108*                              |
| 14  | HZ730127                               |
| 15  | HZ730132*                              |
| 16k | HZ800060                               |
| 17  | HZ800061                               |
| 18  | HZ800062*                              |
| 19  | HZ800082*                              |
| 20  | HZ800081                               |
| 21  | HZ800080                               |
| 22  | HZ800063                               |
| 23  | HZ800064                               |
| 24  | HZ800065                               |
| 25k | HZ800066*                              |
|     | <i>(kit OR DIN)</i>                    |
| 26k | HZ800067                               |
| 27k | HZ800047*                              |
|     | <i>(kit revisione/maintenance kit)</i> |
| 28  | HZ800049                               |
| 29  | HZ800046                               |

1° Stadio Membrana Bilanciata MC5 C E / Balanced Diaphragm 1st Stage MC5 C E

Ed./Issue

01/09

MC5 /C

N° Tav./Rev.

HZXXXXXX\* Contenuto nel kit revisione e non disponibile singolarmente. / Only available in maintenance kit; not available individually. HZXXXXXX Non disponibile / Not available.

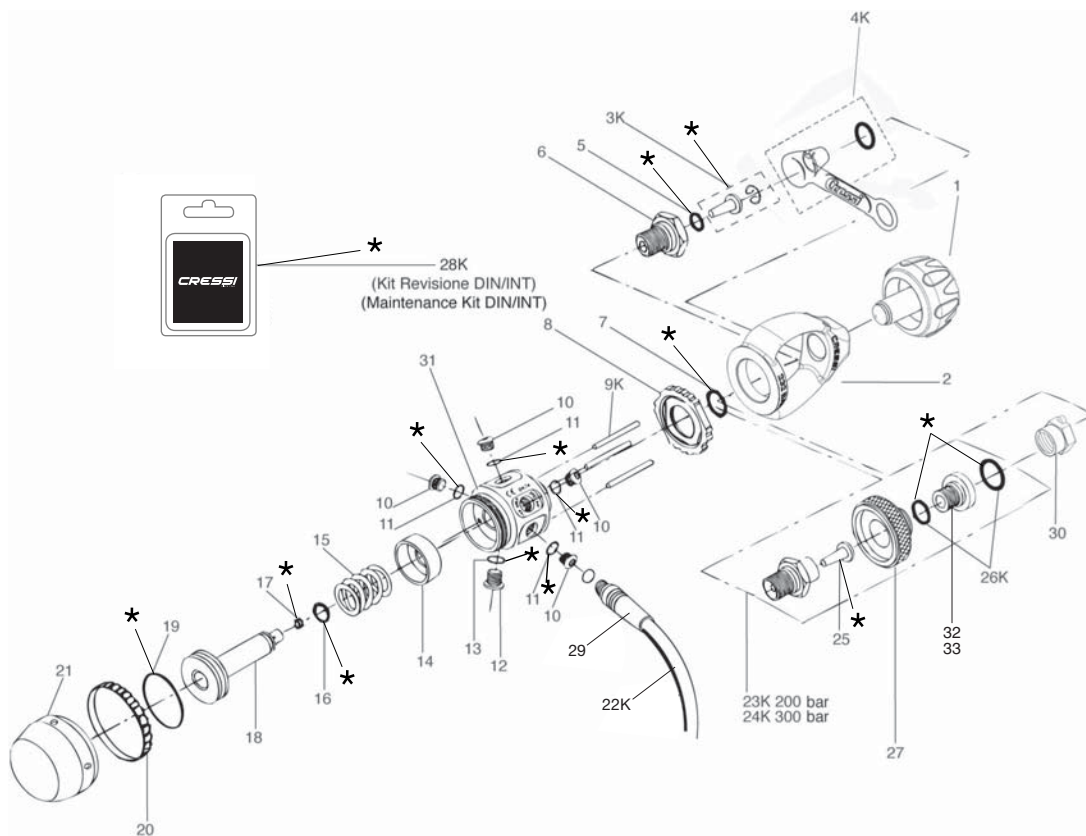

- |     |   |
|-----|---|
| 1   | HZ730027  |
| 2   | HZ700089  |
| 3k  | HZ730188*   |
| 4k  | HZ800090  |
| 5   | HZ730114*   |
| 6   | HZ730151  |
| 7   | HZ735126*   |
| 8   | HZ730152  |
| 9k  | HZ730153  |
| 10  | HZ730106  |
| 11  | HZ730108*   |
| 12  | HZ730127  |
| 13  | HZ730132*   |
| 14  | HZ730154  |
| 15  | HZ730105  |
| 16  | HZ730104*   |
| 17  | HZ730155*   |
| 18  | HZ730156  |
| 19  | HZ735108*   |
| 20  | HZ730157  |
| 21  | HZ730158  |
| 22k | HZ730222 Nero   |
| 22k | HZ730225 Giallo   |
| 23k | HZ735158 (DIN 200 bar)  |
| 24k | HZ735157 (DIN 300 bar)  |
| 25  | HZ735154*   |
| 25k | HZ735195*   |
| 26k | HZ735196 300 bar*   |
| 27  | HZ730159  |
| 28k | HZ730150 INT*<br><small>(kit revisione/maintenance kit)</small>         |
| 28k | HZ730148 DIN 200 bar*<br><small>(kit revisione/maintenance kit)</small> |
| 28k | HZ730149 DIN 300 bar*<br><small>(kit revisione/maintenance kit)</small> |
| 29  | HZ730224  |
| 30  | HZ735170  |
| 31  | HZ730160  |
| 32  | HZ780090  |
| 33  | HZ780093  |

1° Stadio a pistone non Bilanciato AC2 C € /Unbalanced Piston 1<sup>st</sup> Stage AC2 C €

Ed./Issue

01/99

AC2 /B

N° Tav./Rev.

HZXXXXXX\* Contenuto nel kit revisione e non disponibile singolarmente. / Only available in maintenance kit; not available individually. HZXXXXXX Non disponibile / Not available.

**CRESSI**  
SINCE 1946

*Regulators Chart*

**Secondi Stadi**  
**Second Stage**  
**Deuxiemes Etages**  
**Zweite Stufen**  
**Segundas Etapas**  
**ПЕРВЫЕ СТУПЕНИ**  
**二级头**





\* 31K  
(KIT REVISIONE  
MAINTENANCE KIT)

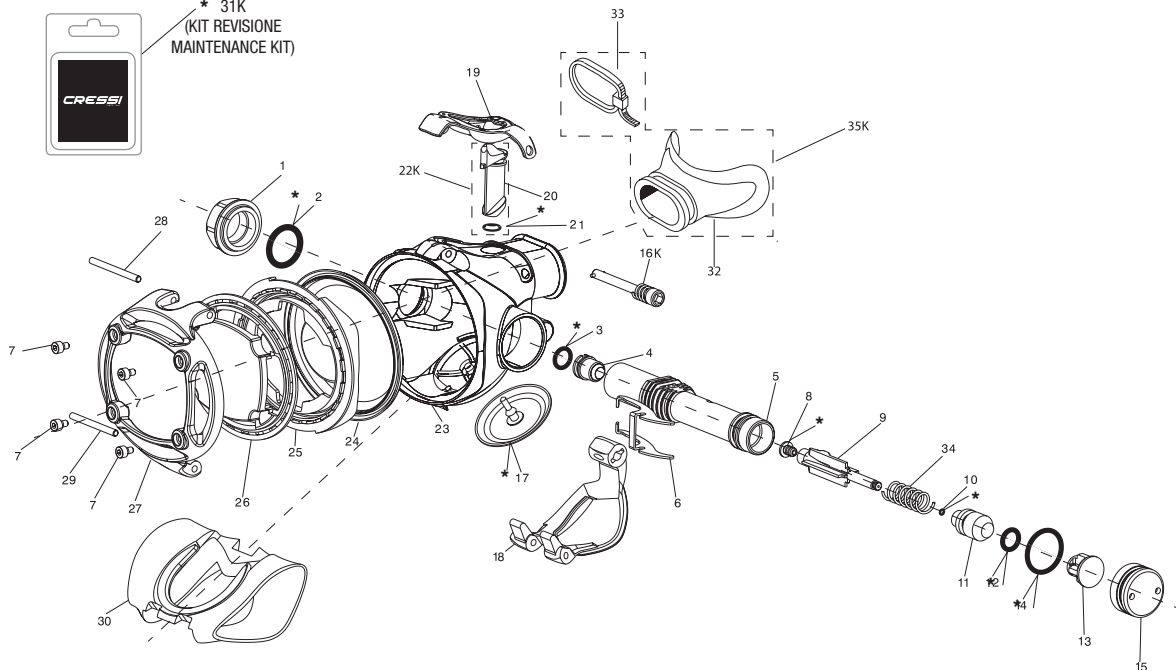

- 1 HZ820050
- 2 HZ820051 \*
- 3 HZ810095
- 4 HZ810094
- 5 HZ820052
- 6 HZ820053
- 7 HZ820087
- 8 HZ820055 \*
- 9 HZ820056
- 10 HZ820057 \*
- 11 HZ820058
- 12 HZ820059 \*
- 13 HZ820083
- 14 HZ820060 \*
- 15 HZ820085
- 16k HZ810077
- 17 HZ782097 \*
- 18 HZ820066
- 19 HZ820067
- 20 HZ820068
- 21 HZ820069 \*
- 22k HZ820070
- 23 HZ820071
- 24 HZ820072
- 25 HZ820073
- 26 HZ820088
- 27 HZ820089
- 28 HZ820076
- 29 HZ820077
- 30 HZ820078
- 31k HZ820080 \*
- 32 HZ790094
- 33 HZ7930202
- 34 HZ820049
- 35k HZ790094

HZXXXXXX\* Contenuto nel kit revisione e non disponibile singolarmente. / Only available in maintenance kit; not available individually. HZXXXXXX Non disponibile/Not available.

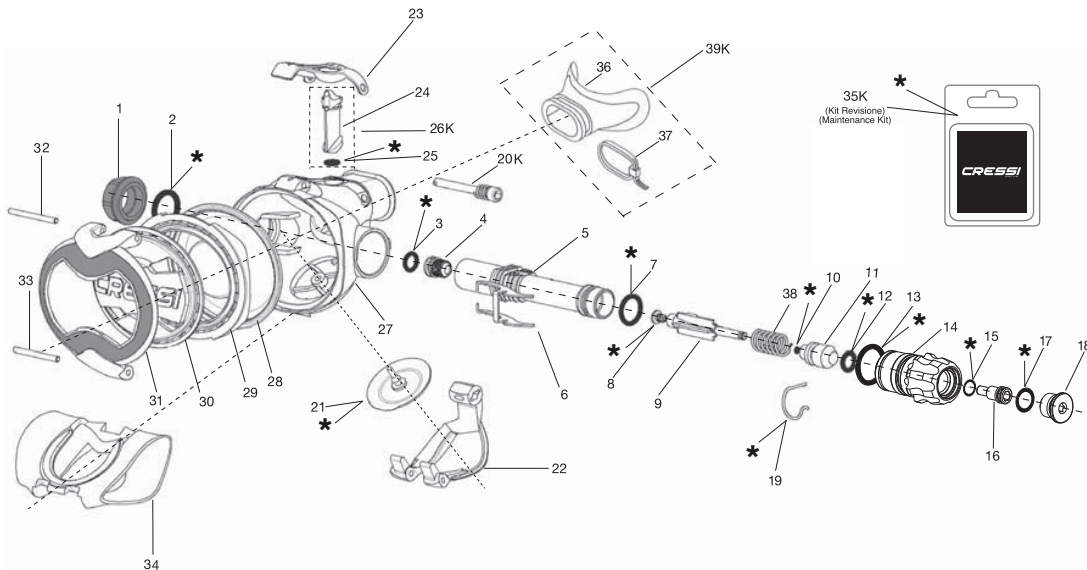

POS	CODE	POS	CODE
1	HZ820050 Titanium	38	HZ820049
1	HZ830101 Steel	39k	HZ790094
2	HZ820051 *		
3	HZ810095 *		
4	HZ810094		
5	HZ820052		
6	HZ820053		
7	HZ820054 *		
8	HZ820055 *		
9	HZ820056		
10	HZ820057 *		
11	HZ820058		
12	HZ820059 *		
13	HZ820060 *		
14	HZ830096		
15	HZ820062 *		
16	HZ820063		
17	HZ730108 *		
18	HZ830097		
19	HZ820065 *		
20k	HZ810077		
21	HZ782097 *		
22	HZ820066		
23	HZ820067		
24	HZ820068		
25	HZ820069 *		
26k	HZ820070		
27	HZ820071		
28	HZ820072		
29	HZ820073		
30	HZ820074		
31	HZ830098 Titanium		
31	HZ830100 Steel		
32	HZ820076		
33	HZ820077		
34	HZ820078		
35k	HZ820080 *		
	<i>(Kit revisione/maintenance kit)</i>		
36	HZ790094		
37	HZ730202		

HZXXXXXX\* Contenuto nel kit revisione e non disponibile singolarmente. / Only available in maintenance kit; not available individually. HZXXXXXX Non disponibile / Not available.

2° Stadio Master regolabile C€ / Master adjustable 2<sup>nd</sup> Stage C€

Ed./Issue

02/15

MAS. /A

N° Tav./Rev.

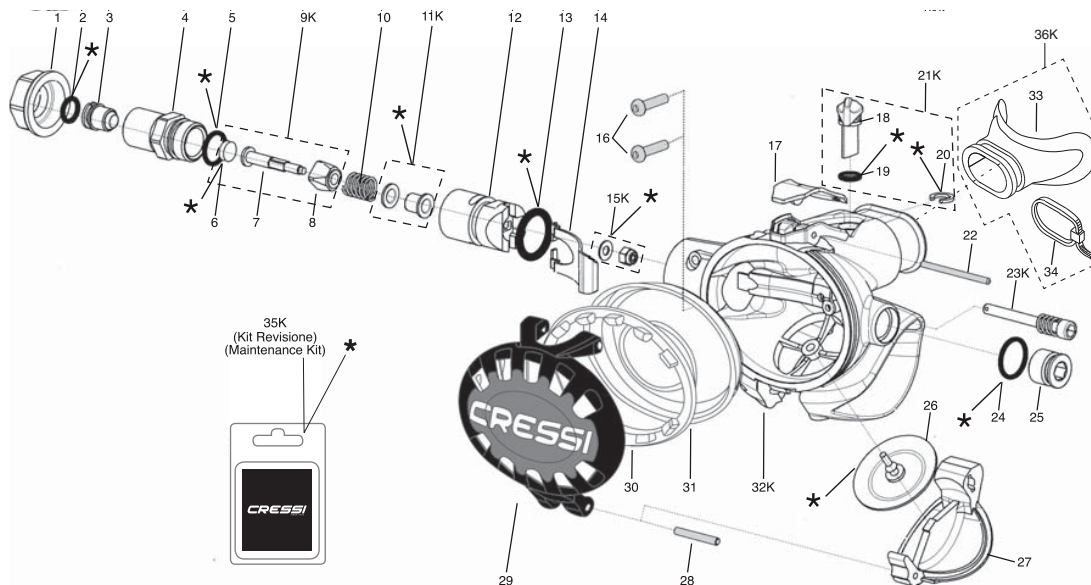

- |     |  |
|-----|--|
| 1   | HZ810096                                     |
| 2   | HZ810095*                                    |
| 3   | HZ810094                                     |
| 4   | HZ810093                                     |
| 5   | HZ810092*                                    |
| 6   | HZ742013*                                    |
| 7   | HZ810091                                     |
| 8   | HZ810090*                                    |
| 9k  | HZ810089*                                    |
| 10  | HZ730207                                     |
| 11k | HZ810088*                                    |
| 12  | HZ810087                                     |
| 13  | HZ810086*                                    |
| 14  | HZ810085                                     |
| 15k | HZ746094*                                    |
| 16  | HZ810084                                     |
| 17  | HZ810083                                     |
| 18  | HZ810082                                     |
| 19  | HZ810081*                                    |
| 20  | HZ810080*                                    |
| 21k | HZ810079*                                    |
| 22  | HZ810078                                     |
| 23k | HZ810077*                                    |
| 24  | HZ810076*                                    |
| 25  | HZ810075                                     |
| 26  | HZ782097*                                    |
| 27  | HZ810073                                     |
| 28  | HZ810072                                     |
| 29  | HZ810063 Nero                                |
| 29  | HZ810065 Giallo<br>(Octopus)                 |
| 30  | HZ810064                                     |
| 31  | HZ810069                                     |
| 32k | HZ810068                                     |
| 33  | HZ790094                                     |
| 34  | HZ730202                                     |
| 35k | HZ810067*<br>(kit revisione/maintenance kit) |
| 36k | HZ790094                                     |

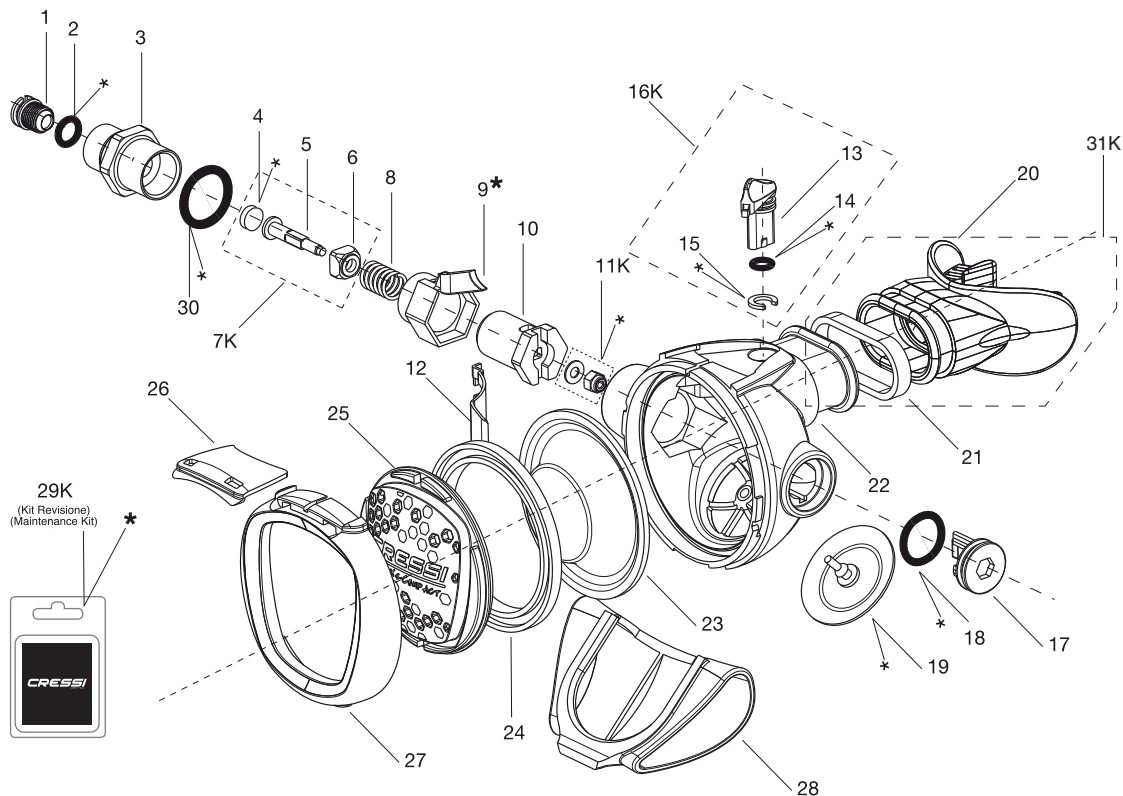

- |     |  |
|-----|--|
| 1   | HZ810094                               |
| 2   | HZ810095*                              |
| 3   | HZ780080                               |
| 4   | HZ742013*                              |
| 5   | HZ780079                               |
| 6   | HZ780078                               |
| 7k  | HZ780077                               |
| 8   | HZ730207                               |
| 9   | HZ780076*                              |
| 10  | HZ780075                               |
| 11k | HZ746094*                              |
| 12  | HZ780074                               |
| 13  | HZ780073                               |
| 14  | HZ820069*                              |
| 15  | HZ810080*                              |
| 16k | HZ780072                               |
| 17  | HZ780071                               |
| 18  | HZ820054*                              |
| 19  | HZ782097*                              |
| 20  | HZ790094                               |
| 21  | HZ730202                               |
| 22  | HZ780070                               |
| 23  | HZ780069                               |
| 24  | HZ780068                               |
| 25  | HZ780067 (Grigio/Gray)                 |
| 25  | HZ780066 (Giallo/Yellow)               |
| 25  | HZ780065 (Rosa/Pink)                   |
| 25  | HZ780064 (Bianco/White)                |
| 25  | HZ780049 (Lilla/Lillic)                |
| 26  | HZ780063                               |
| 27  | HZ780062                               |
| 28  | HZ780061                               |
| 29k | HZ780060*                              |
|     | <i>(kit revisione/maintenance kit)</i> |
| 30  | HZ780059*                              |
| 31k | HZ790094                               |

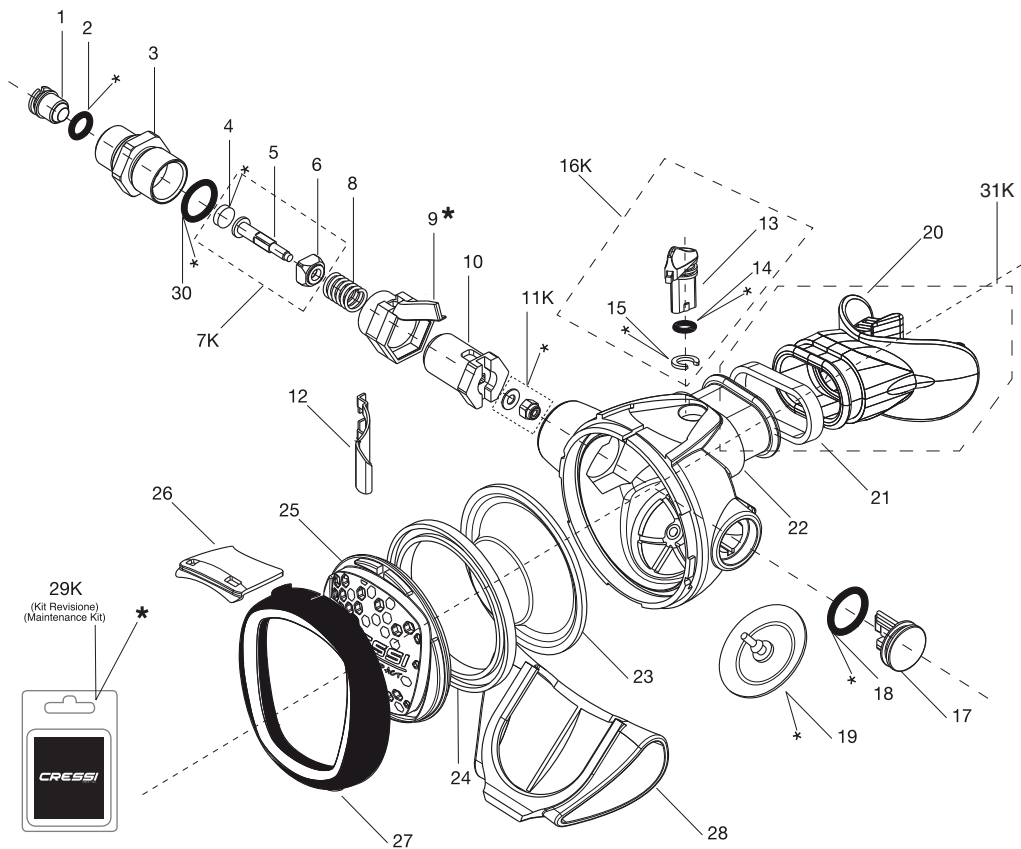

- |     |  |
|-----|--|
| 1   | HZ810094                               |
| 2   | HZ810095*                              |
| 3   | HZ780080                               |
| 4   | HZ742013*                              |
| 5   | HZ780079                               |
| 6   | HZ780078                               |
| 7k  | HZ780077                               |
| 8   | HZ730207                               |
| 9   | HZ780076*                              |
| 10  | HZ780075                               |
| 11k | HZ746094*                              |
| 12  | HZ780074                               |
| 13  | HZ780073                               |
| 14  | HZ820069*                              |
| 15  | HZ810080*                              |
| 16k | HZ780072                               |
| 17  | HZ780071                               |
| 18  | HZ820054*                              |
| 19  | HZ782097*                              |
| 20  | HZ790094                               |
| 21  | HZ730202                               |
| 22  | HZ782099                               |
| 23  | HZ780069                               |
| 24  | HZ780068                               |
| 25  | HZ782096                               |
| 25  | HZ780052 (Octopus)                     |
| 26  | HZ780063                               |
| 27  | HZ782098                               |
| 28  | HZ780061                               |
| 29k | HZ780060*                              |
|     | <i>(kit revisione/maintenance kit)</i> |
| 30  | HZ780059*                              |
| 31k | HZ790094                               |

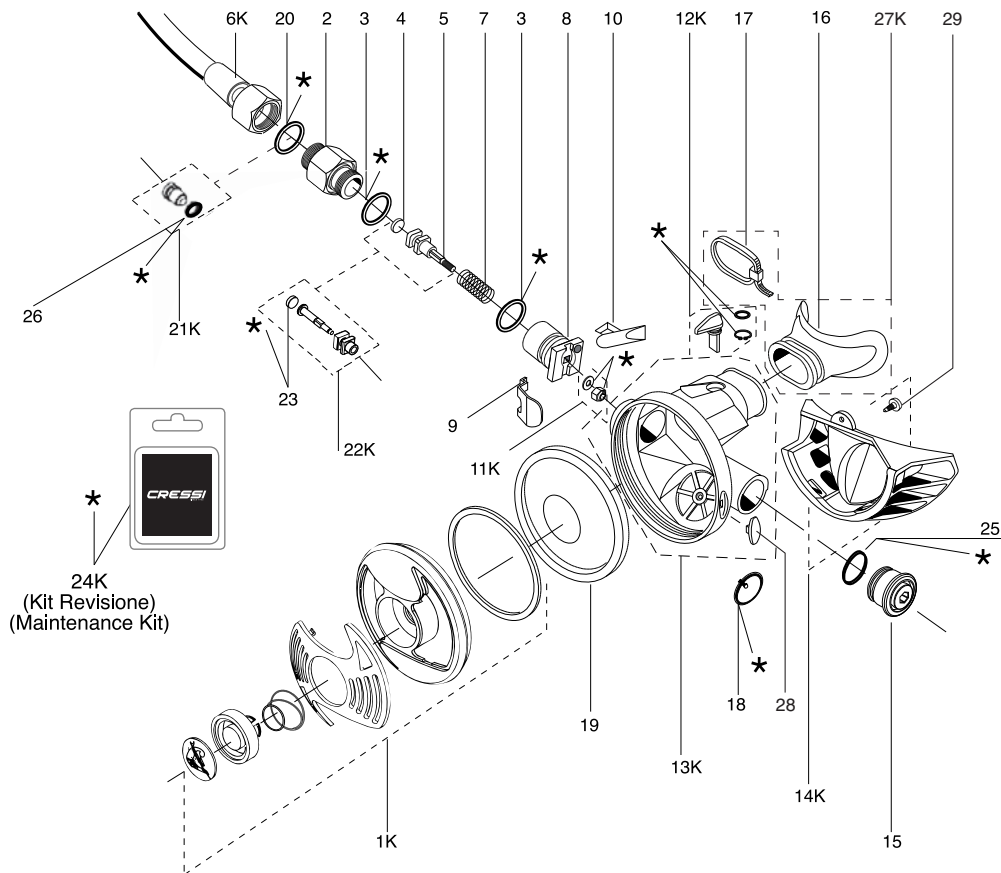

\*  
24K  
(Kit Revisione)  
(Maintenance Kit)

- |     |                                 |
|-----|---------------------------------|
| 1k  | HZ780050 Nero                   |
| 1k  | HZ780051 Giallo                 |
| 2   | HZ742007                        |
| 3   | HZ730218*                       |
| 4   | HZ730208                        |
| 5   | HZ742008                        |
| 6k  | HZ730222 Nero                   |
| 6k  | HZ730225 Giallo                 |
| 7   | HZ730207                        |
| 8   | HZ770096                        |
| 9   | HZ770095                        |
| 10  | HZ770094                        |
| 11k | HZ746094*                       |
| 12k | HZ770099                        |
| 13k | HZ770097                        |
| 14k | HZ790096                        |
| 15  | HZ790095                        |
| 16  | HZ790094                        |
| 17  | HZ730202                        |
| 18  | HZ746006*                       |
| 19  | HZ730212                        |
| 20  | HZ730221*                       |
| 21k | HZ742006                        |
| 22k | HZ742012                        |
| 23  | HZ742013*                       |
| 24k | HZ790090*                       |
|     | (kit revisione/maintenance kit) |
| 25  | HZ790091*                       |
| 26  | HZ790092*                       |
| 27k | HZ790094                        |
| 28  | HZ770054                        |
| 29  | HZ770053                        |



Via Gelasio Adamoli, 501 - 16165 - Genova - Italia

Tel. +39 010 830.79.1 - Fax +39 010 830.79.220

[info@cressi-sub.it](mailto:info@cressi-sub.it) • [www.cressi.com](http://www.cressi.com)