

SUUNTO D6I

USER GUIDE

| | |
|--|----|
| 1. Safety..... | 4 |
| 2. Getting started..... | 7 |
| 2.1. Display states and views..... | 7 |
| 2.2. Icons..... | 7 |
| 2.3. Set up..... | 8 |
| 2.4. Software version check..... | 8 |
| 2.5. Product compatibility..... | 9 |
| 3. Features..... | 11 |
| 3.1. Activation and pre-checks..... | 11 |
| 3.1.1. Wireless Transmitter pre-check..... | 12 |
| 3.1.2. Battery indicators..... | 12 |
| 3.2. Air time..... | 12 |
| 3.3. Alarms, warnings and notifications..... | 13 |
| 3.4. Apnea timer..... | 15 |
| 3.5. Ascent rate..... | 16 |
| 3.6. Backlight..... | 16 |
| 3.7. Bookmarks..... | 17 |
| 3.8. Calendar clock..... | 17 |
| 3.8.1. Time..... | 17 |
| 3.8.2. Date..... | 17 |
| 3.8.3. Units..... | 17 |
| 3.8.4. Dual time..... | 17 |
| 3.8.5. Alarm clock..... | 18 |
| 3.9. Compass..... | 18 |
| 3.9.1. Calibrating compass..... | 19 |
| 3.9.2. Setting declination..... | 19 |
| 3.9.3. Setting compass timeout..... | 19 |
| 3.9.4. Setting bearing lock..... | 20 |
| 3.10. Decompression dives..... | 20 |
| 3.11. Display contrast..... | 23 |
| 3.12. Depth alarm..... | 23 |
| 3.13. Dive history..... | 24 |
| 3.14. Dive modes..... | 26 |
| 3.14.1. Air mode..... | 26 |
| 3.14.2. Nitrox mode..... | 26 |
| 3.14.3. Gauge mode..... | 28 |
| 3.14.4. Free mode..... | 28 |
| 3.15. Dive planning mode..... | 29 |
| 3.16. Dive time alarm..... | 30 |
| 3.17. Error state (algorithm lock)..... | 30 |

| | |
|---|----|
| 3.18. Personal and altitude adjustments..... | 31 |
| 3.19. Safety stops and deepstops..... | 32 |
| 3.20. Sample rate..... | 33 |
| 3.21. Software version..... | 33 |
| 3.22. Stopwatch..... | 33 |
| 3.23. Surface and no-fly time..... | 34 |
| 3.24. Dive numbering..... | 35 |
| 3.25. Suunto RGBM..... | 35 |
| 3.25.1. Diver Safety..... | 36 |
| 3.25.2. Altitude diving..... | 36 |
| 3.25.3. Oxygen exposure..... | 36 |
| 3.26. Tank pressure..... | 37 |
| 3.26.1. Wireless transmission..... | 38 |
| 3.26.2. Installing and pairing transmitter..... | 38 |
| 3.26.3. Transmitted data..... | 39 |
| 3.26.4. Tank pressure alarm..... | 39 |
| 3.27. Tones..... | 40 |
| 3.28. Water contact..... | 40 |
| 4. Care and support..... | 41 |
| 4.1. Handling guidelines..... | 41 |
| 4.2. Water resistance..... | 41 |
| 4.3. Battery replacement..... | 42 |
| 5. Reference..... | 43 |
| 5.1. Technical specifications..... | 43 |
| 5.2. Compliance..... | 45 |
| 5.2.1. CE..... | 45 |
| 5.2.2. EU depth gauge standard..... | 45 |
| 5.3. Trademark..... | 45 |
| 5.4. Patent notice..... | 45 |
| 5.5. International Limited Warranty..... | 45 |
| 5.6. Copyright..... | 46 |
| 5.7. Terms..... | 47 |

1. Safety

Types of safety precautions

 **WARNING:** - is used in connection with a procedure or situation that may result in serious injury or death.

 **CAUTION:** - is used in connection with a procedure or situation that will result in damage to the product.

 **NOTE:** - is used to emphasize important information.

 **TIP:** - is used for extra tips on how to utilize the features and functions of the device.

Before you dive

Make sure that you fully understand the use, displays and limitations of your dive instruments. If you have any questions about this manual or dive computer, contact your Suunto dealer before diving. Always remember that **YOU ARE RESPONSIBLE FOR YOUR OWN SAFETY!**

This dive computer is intended for use with compressed air only.

Safety precautions

 **WARNING:** *ONLY TRAINED DIVERS SHOULD USE A DIVE COMPUTER! Insufficient training for any kind of diving, including freediving, may cause a diver to commit errors, such as incorrect use of gas mixtures or improper decompression, that may lead to serious injury or death.*

 **WARNING:** *You must read the printed quick guide and online user guide for your dive computer. Failure to do so may lead to improper use, serious injury or death.*

 **WARNING:** *THERE IS ALWAYS A RISK OF DECOMPRESSION SICKNESS (DCS) FOR ANY DIVE PROFILE EVEN IF YOU FOLLOW THE DIVE PLAN PRESCRIBED BY DIVE TABLES OR A DIVE COMPUTER. NO PROCEDURE, DIVE COMPUTER OR DIVE TABLE WILL PREVENT THE POSSIBILITY OF DCS OR OXYGEN TOXICITY! An individual's physiological makeup can vary from day to day. The dive computer cannot account for these variations. You are strongly advised to remain well within the exposure limits provided by the instrument to minimize the risk of DCS. As an added measure of safety, you should consult a physician regarding your fitness before diving.*

 **WARNING:** *If you have a pacemaker, we recommend you do not scuba dive. Scuba diving creates physical stresses on the body which may not be suitable for pacemakers.*

 **WARNING:** *If you have a pacemaker, consult a doctor before using this device. The inductive frequency used by the device may interfere with pacemakers.*

⚠ WARNING: Allergic reactions or skin irritations may occur when product is in contact with skin, even though our products comply with industry standards. In such event, stop use immediately and consult a doctor.

⚠ WARNING: Not for professional use! Suunto dive computers are intended for recreational use only. The demands of commercial or professional diving may expose the diver to depths and conditions that tend to increase the risk of decompression sickness (DCS). Therefore, Suunto strongly recommends that the device not be used for any commercial or professional diving activities.

⚠ WARNING: USE BACKUP INSTRUMENTS! Ensure that you use backup instrumentation, including a depth gauge, submersible pressure gauge, timer or watch, and have access to decompression tables whenever diving with a dive computer.

⚠ WARNING: For safety reasons, you should never dive alone. Dive with a designated buddy. You should also stay with others for an extended time after a dive as the onset of possible DCS may be delayed or triggered by surface activities.

⚠ WARNING: PERFORM PRE-CHECKS! Always check that your dive computer is functioning properly and has the correct settings before diving. Check that the display is working, the battery level is OK, tank pressure is correct, and so forth.

⚠ WARNING: Check your dive computer regularly during a dive. If you believe or conclude that there is any problem with any computer function, abort the dive immediately and safely return to the surface. Call Suunto Customer Support and return your computer to an authorized Suunto Service Center for inspection.

⚠ WARNING: THE DIVE COMPUTER SHOULD NEVER BE TRADED OR SHARED BETWEEN USERS WHILE IT IS IN OPERATION! Its information will not apply to someone who has not been wearing it throughout a dive, or sequence of repetitive dives. Its dive profiles must match that of the user. If it is left on the surface during any dive, the dive computer will give inaccurate information for subsequent dives. No dive computer can take into account dives made without the computer. Thus, any diving activity up to four days prior to initial use of the computer may cause misleading information and must be avoided.

⚠ WARNING: DO NOT EXPOSE ANY PART OF YOUR DIVE COMPUTER TO ANY GAS MIX CONTAINING MORE THAN 40% OXYGEN! Enriched air with greater oxygen content presents a risk of fire or explosion and serious injury or death.

⚠ WARNING: DO NOT DIVE WITH A GAS IF YOU HAVE NOT PERSONALLY VERIFIED ITS CONTENTS AND ENTERED THE ANALYZED VALUE INTO YOUR DIVE COMPUTER! Failure to verify tank contents and enter the appropriate gas values where applicable into your dive computer will result in incorrect dive planning information.

⚠ WARNING: Using a dive planner software such as in Suunto DM5 is not a substitute for proper dive training. Diving with mixed gases has dangers that are not familiar to divers diving with air. To dive with Trimix, Triox, Heliox and Nitrox or all of them, divers must have specialized training for the type of diving they are doing.

 **WARNING:** Do not use Suunto USB Cable in areas where flammable gases are present. Doing so may cause an explosion.

 **WARNING:** Do not disassemble or remodel Suunto USB Cable in any way. Doing so may cause an electric shock or fire.

 **WARNING:** Do not use Suunto USB cable if cable or parts are damaged.

 **CAUTION:** DO NOT allow the connector pins of the USB cable to touch any conductive surface. This may short circuit the cable, making it unusable.

Emergency ascents

In the unlikely event that the dive computer malfunctions during a dive, follow the emergency procedures provided by your certified dive training agency to immediately and safely ascend.

2. Getting started

2.1. Display states and views

Suunto D6i has four main modes: **TIME**, **DIVE**, **PLANNING** and **MEMORY**. Change modes by pressing [MODE].

Unless **DIVE** mode is turned off, Suunto D6i automatically switches to **DIVE** mode if you are more than 1.2 m (4 ft) under water.

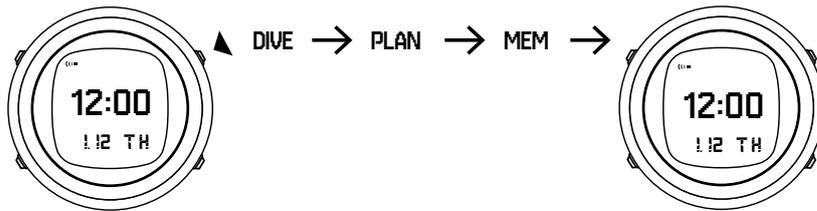

Time and dive modes have different views in the bottom row which you can scroll through with [DOWN] and [UP].

2.2. Icons

Suunto D6i uses the following icons:

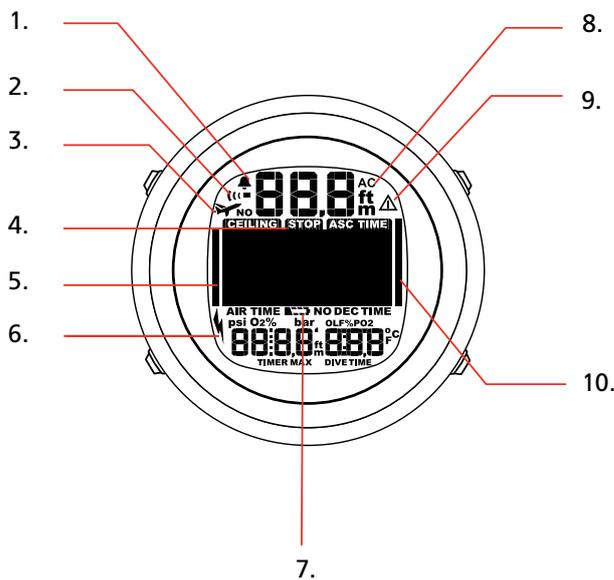

| Icon | Description |
|------|-------------|
| 1 | Daily alarm |
| 2 | Dive alarm |
| 3 | No-fly |

| Icon | Description |
|------|--------------------------------------|
| 4 | Safety stop |
| 5 | Tank pressure (if available) |
| 6 | Wireless transmission (if available) |
| 7 | Low battery |
| 8 | Active water contact |
| 9 | Diver attention symbol |
| 10 | Ascent rate |

2.3. Set up

To get the most out of your Suunto D6i, take some time to read this manual and familiarize yourself with the modes and settings. Make absolutely sure you have it set up as you want before getting into the water.

To get started:

1. Wake up the device by keeping any button pressed until the display turns on.
2. Keep [DOWN] pressed to enter **General Settings**.
3. Set time. See 3.8.1. *Time*.
4. Set date. See 3.8.2. *Date*.
5. Set units. See 3.8.3. *Units*.
6. Press [MODE] to exit settings.

The default dive mode is **Air**. For more information on dive modes, see 3.14. *Dive modes*.

2.4. Software version check

Please note that this user guide is for the latest software version of Suunto D6i. If you have an older version, some features operate differently.

To check the software version:

1. Keep [DOWN] pressed to enter settings.
2. Press [DOWN] to scroll to **Version** and enter with [SELECT].
3. The first line of information indicates the software version.
4. If the version number is **V1.5.x** or higher, you can skip the rest of this section and read the user guide as normal.
5. If the version number is **V1.2.x** please read the sections below regarding how to use specific features.
6. Press [MODE] twice to exit settings.



NOTE: When you send your watch to an authorized Suunto service center for a battery change or other servicing, the software will be updated to the latest version.

Dive modes

Each time you enter dive mode, you have the option of selecting which mode to use.

To change dive modes:

1. While in time mode, press [MODE] to enter dive mode.
2. Scroll to the dive mode you want to use with [UP] or [DOWN].
3. Wait for the pre-checks to complete.

To change settings for a dive mode, keep [DOWN] pressed while in that mode. For further information about dive mode settings, please refer to the respective dive mode section of this user guide.

Stopwatch

Access the stopwatch in time or dive mode as explained in 3.23. *Surface and no-fly time*.

To use the stopwatch:

1. Press [DOWN] to start the stopwatch.
2. While the stopwatch is running, press [DOWN] to take split times.
3. Press [UP] to stop the stopwatch.
4. Keep [UP] pressed to reset the stopwatch.

Apnea timer

Access the apnea timer and adjust settings as explained in 3.4. *Apnea timer*.

To use the apnea timer:

1. Press [DOWN] to start the first interval.
2. Press [DOWN] to start the apnea cycle.
3. Press [DOWN] again to start the next ventilation cycle.
4. Repeat until the end of the defined number of intervals. Press [UP] to pause the timer.
5. Keep [UP] pressed to reset the timer and press [MODE] to exit.

Compass calibration

When you first use the compass, you are prompted to calibrate the compass.

To calibrate the compass:

1. When you see the text **Rotate 360°**, hold the watch level and slowly rotate the watch in a complete circle, keeping display facing up the whole time.
2. When you see the text **Tilt 90°**, slowly tilt the watch up to a vertical position so that the display is facing you.

2.5. Product compatibility

Suunto D6i can be used together with Suunto Wireless Tank Pressure Transmitter for wireless transmission of tank pressure to the dive computer.

You may also connect this dive computer to a PC or Mac with the supplied USB cable and use Suunto DM5 to modify device settings, plan dives, as well as update the dive computer software.

Do not use this dive computer with any unauthorized accessories or equipment not authorized or officially supported by Suunto.

3. Features

3.1. Activation and pre-checks

Unless the dive mode turned off, the dive mode activates automatically when you dive deeper than 1.2 m (4 ft). However, you should switch to dive mode before diving to check altitude and personal settings, battery condition and so on.

Each time your Suunto D6i enters dive mode, a series of automatic checks are performed. All graphical display elements are turned ON, and the backlight and the beep are activated. After this, your altitude and personal settings are displayed along with the maximum operating depth (MOD), gas content, and PO₂ values. Then the battery level is checked.

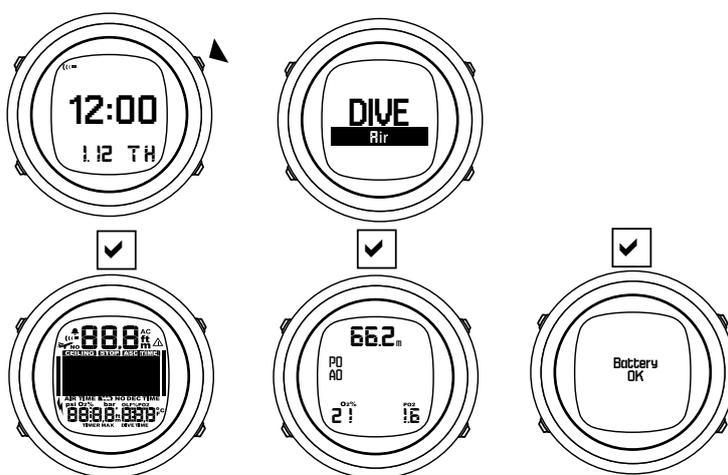

Between consecutive dives, the automatic checks also show current tissue saturation.

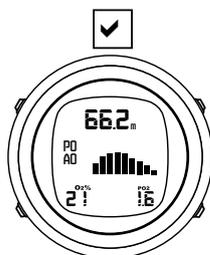

Before leaving on a dive trip, it is highly recommended that you switch to dive mode to make sure everything is functioning properly.

After the automatic checks, Suunto D6i enters surface mode. At this point, you should perform your manual checks before entering the water.

Ensure that:

1. Suunto D6i is in the correct mode and provides complete displays.
2. Altitude setting is correct.
3. Personal setting is correct.
4. Deepstops are set correctly.
5. Unit system is correct.
6. Correct temperature and depth are shown.
7. The alarm beeps.

3.1.1. Wireless Transmitter pre-check

If the optional wireless tank pressure transmitter is used, check that:

1. Tank gas and O₂ settings are correct.
2. The transmitter is properly installed and the tank valve is open.
3. The transmitter and Suunto D6i are paired.
4. The transmitter is sending data (wireless transmission icon blinks, tank pressure is displayed).
5. There is no transmitter low battery warning.
6. There is enough gas for your planned dive. Check the pressure reading against your back-up pressure gauge.

3.1.2. Battery indicators

Temperature or internal oxidation can affect the battery voltage. If you store your Suunto D6i for a long period or use it in cold temperatures, the low battery warning may appear even though the battery has enough capacity.

In these cases, re-enter dive mode and check the battery power. If the battery is low, the Low Battery warning comes on.

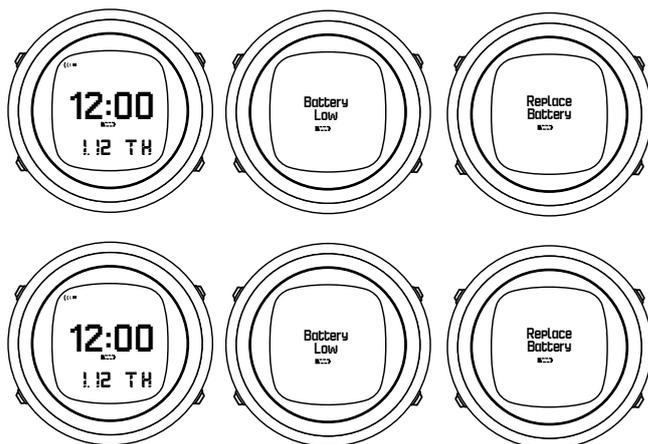

If the low battery icon appears in surface mode, or if the display looks faded, the battery may be too low. Battery replacement is recommended.

 **NOTE:** For safety reasons, the backlight and buzzer (sound) cannot be activated when the low battery warning is displayed.

3.2. Air time

Air time can only be displayed when a wireless tank pressure transmitter is installed and in use.

To activate air time:

1. While in a dive mode, keep [DOWN] pressed.
2. Press [DOWN] to scroll to **Air Time**.
3. Press [UP] to turn on the air time reading.
4. Press [SELECT] .
5. Press [MODE] to exit.

3.3. Alarms, warnings and notifications

Suunto D6i has audible and visual alarms designed to let you know when important limits or presets are being reached.

The two audible alarm types indicating high or low priority:

| Alarm type | Sound pattern | Duration |
|---------------|---|---------------------------|
| High priority |  | 2.4 s sound + 2.4 s break |
| Low priority |  | 0.8 s sound + 3.2 s break |

In addition, there are three audible guidance notifications:

| Instructional beep | Sound pattern | Interpretation |
|----------------------|---|------------------|
| Ascending |  | Start ascending |
| Descending |  | Start descending |
| Descending-ascending |  | Change gas |

Suunto D6i displays information during the alarm breaks in order to save battery life.

High priority alarms:

| Alarm | Explanation |
|---|---|
| High priority alarm followed by 'Start ascending' beep, repeated for maximum three minutes PO ₂ value blinks | PO ₂ value greater than the adjusted value. Current depth is too deep for the gas in use. You should immediately ascend or change to a lower O ₂ % gas. |
| High priority alarm followed by 'Start descending' beep, repeated for maximum three minutes Er blinks and an arrow points downwards. | Decompression ceiling depth exceeded. You should immediately descend to, or below, the ceiling. |
| High priority alarm, repeated three times. SLOW blinks. | Maximum ascent rate of 10 m/min (33 ft/min) exceeded. Slow down your ascent rate. |

Low priority alarms:

| Alarm type | Alarm reason |
|---|---|
| Low priority alarm followed by 'Change gas' beep. Gas mix O ₂ % value blinks. | Gas change recommended (Nitrox dive mode only). You should change to a gas more favorable to decompression. ASC TIME assumes that the gas is changed |

| Alarm type | Alarm reason |
|---|--|
| | and is accurate only if you change the gas accordingly. |
| <p>Low priority alarm followed by 'Start ascending' beep, sounded two times.</p> <p>ASC TIME blinks and an arrow points upwards.</p> | <p>No-decompression dive becomes a decompression stop dive. Depth is below the decompression floor level. You should ascend to, or above, the floor.</p> |
| <p>Low priority alarm followed by 'Start descending' beep.</p> <p>DEEPSTOP blinks and an arrow points downwards.</p> | <p>Mandatory deepstop violated. You should descend to complete the deepstop.</p> |
| <p>Low priority alarm followed by 'Start descending' beep, repeated for three minutes.</p> <p>An arrow points downwards.</p> | <p>Mandatory safety stop violated. You should descend to complete the safety stop.</p> |
| <p>Low priority alarm followed by two short beeps.</p> <p>DEEPSTOP and timer displayed.</p> | <p>Deepstop depth reached. Make the mandatory deepstop for the duration shown by the timer.</p> |
| <p>Low priority alarm, repeated twice.</p> <p>Tank pressure value blinks.</p> | <p>Tank pressure reaches the defined alarm pressure or the fixed alarm pressure, 50 bar (700 psi). Acknowledge the alarm by pressing any button.</p> |
| <p>Low priority alarm, repeated twice.</p> <p>OLF% value blinks if PO₂ value is greater than 0.5 bar.</p> | <p>OLF value at 80% or 100% (Nitrox dive mode only). Acknowledge the alarm by pressing any button.</p> |
| <p>Low priority alarm, repeated twice.</p> <p>Maximum depth value blinks</p> | <p>Defined maximum depth or the maximum depth of the device exceeded. Acknowledge the alarm by pressing any button.</p> |
| <p>Low priority alarm, repeated twice; dive time value blinks</p> | <p>Defined dive time exceeded. Acknowledge the alarm by pressing any button.</p> |
| <p>Low priority alarm. Maximum depth value blinks.</p> | <p>Defined depth reached (Free dive mode only). Acknowledge the alarm by pressing any button.</p> |
| <p>Low priority alarm,</p> <p>Surface time value blinks.</p> | <p>Duration of surface time until next dive (Free dive mode only). Acknowledge the alarm by pressing any button.</p> |

Visual alarms

| Symbol on display | Indication |
|--|---|
| △ | Attention - extend surface interval |
| ER | Violated decompression ceiling or bottom time is too long |
|  NO | Do not fly |

3.4. Apnea timer

You can use the apnea timer for interval training when freediving. You can adjust the following settings:

- **Vent.:** ventilation time; this is the starting duration of the time your breathing time. The time is increased by the increment time for each interval.
- **Incr:** increment time; this is added to the ventilation time for each interval. For example, if your ventilation time is 1:00 minute and your increment time is 0:30 seconds, the first interval ventilation is 1:00, the second is 1:30, the third is 2:00, and so on.
- **Repeats:** number of intervals

To adjust apnea timer settings:

1. While in time mode, keep [UP] pressed to enter the apnea timer view.

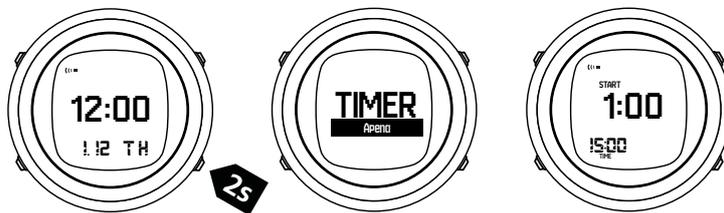

2. Keep [DOWN] pressed to enter apnea timer settings.
3. Adjust the ventilation time with [UP] or [DOWN] and confirm with [SELECT] .
4. Adjust the increment time with [UP] or [DOWN] and confirm with [SELECT] .
5. Adjust the number of intervals with [UP] or [DOWN] and confirm with [SELECT] .

To use the apnea timer:

1. Press [SELECT] to start the first interval. The timer counts down the ventilation time. The countdown continues up to -0:30 seconds beyond the defined ventilation time.
2. Press [SELECT] to start the apnea cycle. You can start this at any time during the ventilation countdown. The apnea time is not defined in the watch. It is as long or short as you choose.
3. Press [SELECT] again to start the next ventilation cycle.
4. Repeat until the end of the defined number of intervals.
5. Press [MODE] to exit the apnea timer.

You can reset the apnea timer by keeping [SELECT] pressed.

The apnea timer supports up to 20 intervals, but this is dependent on the ventilation and increment times. The last ventilation cycle cannot be shorter than 0:05 seconds or longer than 20:00 minutes.

⚠ WARNING: *Anyone who engages in any form of breath hold diving is in danger of shallow-water blackout (SWB), the sudden loss of consciousness caused by oxygen starvation.*

3.5. Ascent rate

The ascent rate is displayed as a vertical bar along the right side of the display.



When the maximum allowed ascent rate is exceeded, the lower segment of the bar starts to blink and the top segment stays solid.



Continuous ascent rate violations result in mandatory safety stops. See 3.19. *Safety stops and deepstops* .

⚠ WARNING: *DO NOT EXCEED THE MAXIMUM ASCENT RATE! Rapid ascents increase the risk of injury. You should always make the mandatory and recommended safety stops if you have exceeded the maximum recommended ascent rate. If the mandatory safety stop is not completed, the decompression algorithm penalizes your next dive(s).*

3.6. Backlight

To active the backlight while diving, press [MODE] .

Otherwise, keep [MODE] pressed until the backlight activates to use the backlight.

You can define how long the backlight stays on when you activate it or turn the backlight off altogether.

To set backlight duration:

1. While in time mode, keep [DOWN] pressed.
2. Press [DOWN] to scroll to **BACKLIGHT** and press [SELECT] .
3. Set duration or turn off with [DOWN] or [UP] .
4. Press [MODE] to save and exit to settings.

📄 NOTE: *When the backlight is off, it does not illuminate when an alarm sounds.*

3.7. Bookmarks

At any time during a dive, you can add a bookmark to the dive log by pressing [SELECT].

You can view bookmarks when scrolling the dive profile in the logbook.

Each bookmark records present depth, time, water temperature, heading (if the compass is enabled), and tank pressure (if available).

3.8. Calendar clock

The calendar clock is the default mode of Suunto D6i.

3.8.1. Time

In the time settings, you can set the hours, minutes, seconds, and format (12 or 24-hour).

To set time:

1. While in time mode, keep [DOWN] pressed.
2. Press [UP] to scroll to **Time** and press [SELECT].
3. Set hours with [DOWN] or [UP] and confirm with [SELECT].
4. Repeat for minutes and seconds. Set the format with [DOWN] or [UP] and confirm with [SELECT].
5. Press [MODE] to exit.

3.8.2. Date

The date and weekday are shown in the bottom row of time mode. Press [DOWN] to toggle between views.

To set the date:

1. While in time mode, keep [DOWN] pressed.
2. Press [UP] to scroll to **Date** and press [SELECT].
3. Set year with [DOWN] or [UP] and accept with [SELECT].
4. Repeat for month and day.
5. Press [MODE] to exit.

3.8.3. Units

In the units setting, choose whether the units are displayed in the metric or Imperial system.

1. While in time mode, keep [DOWN] pressed.
2. Press [UP] to scroll to **Units** and press [SELECT].
3. Press [DOWN] to toggle between **Metric** and **Imperial** and confirm with [SELECT].
4. Press [MODE] to exit.

3.8.4. Dual time

Dual time allows you to keep track of the time in a second time zone. Dual time is shown in the bottom left of the time mode display by pressing [DOWN].

To set dual time:

1. While in time mode, keep [DOWN] pressed.
2. Press [UP] to scroll to **Dual Time** and press [SELECT].

3. Set hours with [DOWN] or [UP] and confirm with [SELECT] .
4. Repeat for minutes.
5. Press [MODE] to exit.

3.8.5. Alarm clock

Suunto D6i has a daily alarm which can be set to activate once, on weekdays or every day.

When the daily alarm activates, the screen blinks and the alarm sounds for 60 seconds. Press any button to stop the alarm.

To set the daily alarm:

1. While in time mode, keep [DOWN] pressed.
2. Press [UP] to scroll to **Alarm** and press [Select.]
3. Select alarm activation with [DOWN] or [UP] and confirm with [Select] . The options are **OFF**, **ONCE**, **WEEKDAYS**, or **EVERY DAY**.
4. Set hours with [DOWN] or [UP] and confirm with [SELECT] .
5. Repeat for minutes.
6. Press [MODE] to exit.

3.9. Compass

Suunto D6i includes a digital compass.

The tilt-compensated compass gives you accurate readings even if the compass is not horizontally level.

The compass can be activated from either time or dive mode and shows the current bearing and depth.

1. While in TIME or DIVE mode, keep [SELECT] pressed to activate the compass.

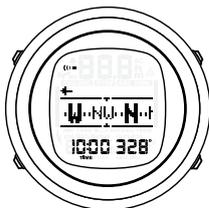

2. Press [MODE] to exit the compass display. If you are underwater, keep [SELECT] pressed to exit.

When in dive mode, the compass display includes additional information in the bottom left and right views.

1. Press [DOWN] to scroll through the bottom left views. (tank pressure, max. depth, time)
2. Press [UP] to scroll through the bottom right views. (dive time, temperature, bearing)



3.9.1. Calibrating compass

When you first start using Suunto D6i, the compass needs to be calibrated. Suunto D6i displays the calibration icon when you enter the compass.

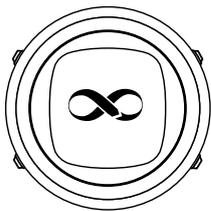

Calibrate the compass by slowly rotating the unit in your hand in large figure-8 loops..

During the calibration process, the compass adjusts itself to the surrounding magnetic field.

If the calibration fails, **Try Again** appears. If calibration continues to fail, move to another location and try again.

When traveling overseas, it is recommended that you recalibrate the compass at the new location before using it.

To manually start the calibration:

1. While in the compass view, keep [DOWN] pressed.
2. Press [DOWN] to scroll to **Calibration**.
3. Press [SELECT] to start the calibration.

3.9.2. Setting declination

You should always adjust your compass declination for the area where you are diving to get accurate heading readings. Check the local declination from a trusted source and set the value in Suunto D6i.

1. While in the compass view, keep [DOWN] pressed.
2. Press [DOWN] to scroll to **DECLINATION** and press [SELECT] .
3. Press [DOWN] to toggle to **East** or **West** and confirm with [SELECT] .
4. Set **Declination Degrees** with [DOWN] or [UP] .
5. Press [MODE] to save and exit.

3.9.3. Setting compass timeout

You can define how long the compass stays on after you have activated it. Reset the timeout with any button press while using the compass.

After the timeout, the Suunto D6i returns to time or dive mode.

To set the timeout:

1. While in the compass display, keep [DOWN] pressed.

2. Press [DOWN] to scroll to **Timeout** and press [SELECT].
3. Adjust the timeout time with [DOWN] or [UP].
4. Press [MODE] to exit.

3.9.4. Setting bearing lock

A bearing is the angle between north and your target. In simple terms, it is the direction you want to travel. Your heading, on the other hand, is your actual direction of travel.

The default bearing is North.

You can set a bearing lock to help you orientate yourself underwater and ensure you maintain your direction of travel. For example, you can set a bearing lock for the direction to a reef before leaving the boat.

The last locked bearing is stored and available the next time the compass is activated. In **DIVE** mode, the locked bearings are also stored in the log. To lock a bearing:

1. With the compass active, hold the watch in front of you and turn yourself towards your target.
2. Press [SELECT] to lock the current degree displayed on the watch as your bearing.
3. Press [SELECT] to clear the lock.

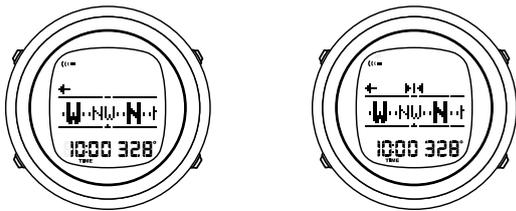

If, at any point, your bearing moves outside the compass display, right or left arrows appear to show turn direction.

Suunto D6i provides help for navigating square and triangular patterns, as well as navigating a return heading with the following symbols.

| Symbol | Explanation |
|--------|---|
| ⏪⏩ | You are traveling towards the locked bearing. |
| ◻ | You are 90 (or 270) degrees from the locked bearing. |
| ◻ | You are 180 degrees from the locked bearing. |
| ◻ | You are 120 (or 240) degrees from the locked bearing. |

3.10. Decompression dives

If you exceed the no-decompression limit on a dive, when **NO DEC TIME** reaches zero, your dive changes into a decompression dive. Therefore, you must perform one or more decompression stops on your way to the surface.

When the decompression dive starts, the **NO DEC TIME** on your display is replaced by **ASC TIME**, and a CEILING indicator appears. An upward pointing arrow also prompts you to start your ascent.

Suunto D6i provides the decompression information required for ascent with two key values:

- **CEILING**: depth that you should not go above
- **ASC TIME**: optimum ascent time in minutes to surface with defined gases

If you exceed the no-decompression limits on a dive, the dive computer provides the decompression information required for ascent along with subsequent details that are updated as you ascend.

In other words, rather than requiring you to make stops at fixed depths, the dive computer lets you decompress within a range of depths. This is known as continuous decompression.

Ceiling, ceiling zone, floor and decompression range

Before you do a decompression dive, you need to understand the meaning of ceiling, ceiling zone, floor, and decompression range. You need to understand these concepts to be able to correctly interpret the guidance provided by the dive computer.

- The *ceiling* is the shallowest depth to which you should ascend when doing decompression.
- The *ceiling zone* is the optimum decompression depth range. It is the range between the ceiling depth and 1.2 m (4 ft) below that ceiling.
- The *floor* is the deepest depth at which the decompression stop time does not increase. Decompression starts when you pass this depth during your ascent.
- The decompression range is the depth range between the ceiling and floor. Within this range, decompression takes place. However, it is important to remember that the decompression is slower at or close to the floor compared to the ceiling zone.

The depth of the ceiling and floor depends on your dive profile. The ceiling depth is fairly shallow when you first enter the decompression dive. But if you remain at depth, the ceiling depth moves downward, and the ascent time increases. The opposite is also true: the floor and ceiling depths may change upwards while you are decompressing.

When conditions are rough, it may be difficult to maintain a constant depth near the surface. In such cases, it is more manageable to maintain a depth somewhat below the ceiling, to ensure that the waves do not lift you above the ceiling. Suunto recommends that you decompress deeper than 4 m (13 ft), even if the indicated ceiling is shallower.

Ascent time

The ascent time shown on your dive computer is the minimum amount of time needed to reach the surface on a decompression dive. This includes:

- Time required to do deepstops
- Ascent time from depth at an ascent rate of 10 m (32.8 ft) per minute
- Time needed for decompression
- Time needed for extra safety stops if ascending too fast during the dive

 **WARNING:** *Your actual ascent time may be longer than displayed by Suunto D6i. It may be longer if your ascending speed is slower than 10 m (32.8 ft) per minute or you are doing a decompression stop deeper than the recommended ceiling. Take this into account, since it might increase the amount of required breathing gas to reach the surface.*

Decompression guidance

On a decompression dive, there can be three kinds of stops:

- Safety stop
- Deepstop
- Decompression stop

Though not recommended, you may break (ignore) deepstops and safety stops. Suunto D6i penalizes such actions with additional stops or other measures, either during the dive or on following dives. For more information, see 3.19. *Safety stops and deepstops.*

Suunto D6i shows the ceiling value always from the deepest of these stops. Deepstop and safety stop ceilings are always at constant depth when you are at the stop. Stop time is counted down in minutes and seconds.

With decompression stops, the ceiling is always decreasing while you are near the ceiling depth, providing continuous decompression with optimum ascent time.

 **NOTE:** *It is always recommended to keep close to the decompression ceiling when ascending.*

Below the floor

The blinking **ASC TIME** text and an upward arrow indicate that you are below the floor. A low priority alarm will also sound. You should start your ascent immediately. The ceiling depth is shown on the left side of the center field, and the minimum total ascent time on the right side.

Below is an example of a decompression dive with a ceiling of 3 m and total ascent time of 9 minutes.



CEILING STOP ASC TIME
3.0 9

Above the floor

When you ascend above the floor, the **ASC TIME** text stops blinking and the upward arrow disappears, as shown below.



CEILING STOP ASC TIME
3.0 9

This indicates you are in the decompression range. Decompression begins, but slowly. Therefore, you should continue your ascent.

At the ceiling

When you reach the ceiling zone, the display will show you two arrows pointing at each other as shown below.



During the decompression stop, your total ascent time continues to count down towards zero. If the ceiling moves upwards, you can ascend to the new ceiling.

You may surface only after **ASC TIME** and **CEILING** have disappeared. This means that the decompression stop and any mandatory safety stop have been completed.

You are advised, however, to stay below the ceiling until the **STOP** text has also disappeared. This indicates that the three (3) minute recommended safety stop has also been completed.

Above the ceiling

If you ascend above the ceiling during a decompression stop, a downward arrow appears in front of the ceiling depth, and a continuous beeping starts.



In addition, an error warning **ER** reminds you that you have only three (3) minutes to correct the situation. You must immediately descend to, or below, the ceiling. If you continue to violate the decompression, the dive computer goes into a permanent error mode (3.17. *Error state (algorithm lock)*).

3.11. Display contrast

You can adjust the contrast of the display according to your preference or, for example, to suite changing dive conditions.

1. While in time mode, keep [DOWN] pressed.
2. Press [UP] to scroll to **Contrast** and press [Select] .
3. Use [DOWN] or [UP] to change the contrast from 0 (lowest) to 10 (highest).
4. Press [MODE] to exit.

3.12. Depth alarm

By default the depth alarm sounds at 30 m (100 ft). You can adjust the depth according to your personal preference or switch it off.

To adjust the depth alarm:

1. While in a dive mode, keep [DOWN] pressed to enter settings.
2. Press [UP] to scroll to **Depth Alarm** and press [SELECT] .
3. Press [UP] to toggle the alarm on/off and confirm with [SELECT] .
4. Adjust depth with [DOWN] or [UP] and accept with [SELECT] .
5. Press [MODE] to exit.

When the depth alarm activates, the backlight blinks and the low priority audible alarm pattern sounds. Acknowledge the alarm by pressing any button.

3.13. Dive history

Suunto D6i has a detailed logbook and dive history available in memory mode.

The logbook contains a sophisticated dive profile for each recorded dive. The time between each data point saved in the log is based on the configurable sample rate (see 3.20. *Sample rate*).

The dive history is a summary of all recorded dives.

To access dive history:

1. Press [MODE] until you see **MEM**.
2. Switch between **History** and **Logbook** with [DOWN] or [UP] .
3. When you are viewing the history or logbook, you can press [MODE] to go back and select the other one. Press [MODE] a second time to exit.

History

When you have entered the dive history view, you can switch between **Scuba History** and **FREE DIVE HISTORY** with [DOWN] and [UP] .

Scuba dive history shows you a summary of the following:

- Dive hours
- Total number of dives
- Maximum depth

The scuba dive history records a maximum of 999 dives and 999 diving hours. When these limits are reached, the counters reset to zero.

Free dive history shows the following:

- the deepest and the longest dives of all free dives
- the cumulative dive time in hours and minutes
- the total number of dives

The free dive history records a maximum of 999 dives and 99:59 diving hours. When these limits are reached, the counters are reset to zero.

Logbook

To access the logbook:

1. Press [MODE] three time until you come to **MEM** mode.
2. Press [UP] to choose **Logbook**.
3. Press [DOWN] or [UP] to scroll to the log you wish to look at and press [SELECT] .
4. Press [SELECT] to scroll through the pages.
5. Press [MODE] to exit.

Each log has three pages:

1. Main page



- maximum depth
- date of dive
- type of dive (indicated by first letter of dive mode, such as **A** for **Air** mode)
- dive start time
- dive number – from oldest to newest
- gas percentage(s) of the first used gas mix
- total dive time (in minutes in all modes)
- Surface time and warnings page



- maximum depth
- surface time after previous dive
- average depth
- consumed pressure (if enabled)
- warnings
- OLF% (if applicable)
- Dive profile graph



- water temperature
- tank pressure (if enabled)
- depth/time profile of the dive

Press [UP] to step through the dive profile graph or keep [UP] pressed to auto-scroll.

The dive profile graph shows point by point dive information such as depth, compass heading, decompression info, ceiling and ascent time.

The **End of Logs** text is displayed between the oldest and most recent dive.

The logbook capacity depends on the sample rate.

If the memory is full, when new dives are added, the oldest dives are deleted.

The contents of the memory remain when the battery is changed (providing that the battery has been replaced according to the instructions).

 **NOTE:** Several repetitive dives are considered to belong to the same repetitive dive series if the no-fly time has not ended.

3.14. Dive modes

Suunto D6i has the following dive modes:

- **Air:** for diving with regular air
- **Nitrox:** for diving using oxygen-enriched gas mixtures
- **Gauge:** for using the dive computer as a bottom timer
- **Free:** for freediving
- **Off:** turns dive mode off completely; the dive computer does not automatically switch the dive mode when submerged and dive planning mode is hidden

By default, **Air** mode is activated when you enter dive mode. You can change which mode is activated or turn dive mode off under the general settings.

To change dive modes:

1. While in time mode, keep [DOWN] pressed.
2. Press [SELECT] to enter **Dive Mode**.
3. Change to the desired mode with [UP] or [DOWN] and confirm with [SELECT] .
4. Press [MODE] to exit.

Each dive mode has its own settings which you need to adjust while in the given mode.

To modify dive mode settings:

1. While in a given dive mode, keep [DOWN] pressed.
2. Press [DOWN] or [UP] to scroll through the settings.
3. Press [SELECT] to enter a setting.
4. Adjust the setting with [DOWN] or [Up] and confirm with [SELECT] .
5. Press [MODE] to exit.



NOTE: Some settings cannot be changed until five (5) minutes have elapsed after the dive.

3.14.1. Air mode

Air mode is for diving with regular air and has the following settings:

- Personal/altitude adjustment (see 3.18. *Personal and altitude adjustments*)
- Tank pressure (see 3.26. *Tank pressure*)
- Tank pressure alarm (see 3.26.4. *Tank pressure alarm*)
- Depth alarm (see 3.12. *Depth alarm*)
- Dive time alarm (see 3.16. *Dive time alarm*)
- Sample rate (see 3.20. *Sample rate*)
- Deepstop (see 3.19. *Safety stops and deepstops*)
- Air time (see 3.2. *Air time*)

3.14.2. Nitrox mode

Nitrox mode is for diving with oxygen-enriched gas mixtures.

Diving with Nitrox allows you to increase bottom times or reduce the risk of decompression illness. However, when the gas mix is altered or depth increased, the oxygen partial pressure is generally increased. Suunto D6i provides you with information to adjust your dive and stay within safe limits.

Nitrox mode has the following settings

- Nitrox (gas mixture): define up to three mixes
- Personal/altitude adjustment (see 3.18. *Personal and altitude adjustments*)
- Depth alarm (see 3.12. *Depth alarm*)
- Dive time alarm (see 3.16. *Dive time alarm*)
- Sample rate (see 3.20. *Sample rate*)
- Deepstop (see 3.19. *Safety stops and deepstops*)
- Air time (see 3.2. *Air time*)

In Nitrox mode, both the percentage of oxygen in your tank and the oxygen partial pressure limit must be entered into Suunto D6i.

This ensures correct nitrogen and oxygen calculations and the correct maximum operating depth (MOD), which is based on your entered values.

The default oxygen percentage (O₂%) setting is 21% (air) and oxygen partial pressure (PO₂) setting is 1.4 bar (20 psi).

The gas mixes may be tagged as **Primary**, **Secondary** or **Off**. One of the gases is always set as **Primary** and the other gases may have any status. The decompression calculation is based on mixes that are defines as **Primary** gases.

To modify gas mix settings:

1. While in Nitrox mode, keep [DOWN] pressed.
2. Press [SELECT] to enter the **Nitrox** setting.
3. Scroll to **Mix1**, **Mix2** or **Mix3** as desired and press [SELECT] .
4. Define the selected mix as **Primary**, **Secondary** or **Off** with [UP] or [DOWN] and confirm with [SELECT] .

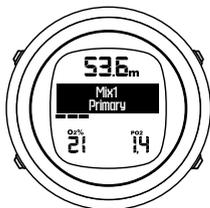

5. Adjust the blinking O₂ value with [DOWN] or [UP] to match the oxygen % of your tank and accept with [SELECT] .
6. Adjust the blinking PO₂ (oxygen partial pressure) value with [DOWN] or [Up] and confirm with [SELECT] .
7. Adjust other mix settings as needed.
8. Press [MODE] to exit.

 **NOTE:** If the oxygen content of a mix is set to 22% or above, the setting value remains until changed. It does not automatically revert back to 21%.

3.14.2.1. Changing gases on multi-gas dives

If you have using more than one gas on a dive, Suunto D6i allows you to change enabled gas mixes during the dive.

A dive is always started with **Mix1**. You can change to another enabled mix that is within the set maximum oxygen partial pressure. The tissue calculation during the dive is based on the mixes you have selected as **Primary** gases.

To change gases during a dive:

1. Keep [UP] pressed.
2. Scroll through the enabled mixes with [UP] or [DOWN] and select the gas you want to use with by pressing [SELECT] .

 **NOTE:** If no button is pressed within 15 seconds, the dive computer goes back to the dive display without changing the gas mix.

The mix number, O₂% and PO₂ for the mixes are shown when scrolling. If the set PO₂ limit is exceeded, the PO₂ value blinks. You cannot change to the gas in this case. The mix is shown, but you cannot select it to use.

When ascending, Suunto D6i prompts you to change gas when the PO₂ level you have set for the next mix allows a gas change.

3.14.3. Gauge mode

With **Gauge** mode, you can use Suunto D6i as a bottom timer.

The timer in the center of the display shows dive time in minutes and seconds and activates at the start of the dive. The total running dive time, in minutes, is in the lower right corner.

The timer in the center of the display can be used as a stopwatch by pressing [SELECT] during the dive.

Pressing [SELECT] resets the main timer and adds a bookmark to the dive log. The previously-timed interval is displayed below the main timer.



Gauge mode has the following settings

- Depth alarm (see 3.12. *Depth alarm*)
- Dive time alarm (see 3.16. *Dive time alarm*)
- Sample rate (see 3.20. *Sample rate*)

Gauge mode is a bottom timer only and thus includes no decompression information or calculations.

3.14.4. Free mode

With **Free** mode, Suunto D6i can be used as a freediving instrument. The dive time is indicated in minutes and seconds in the center of the display.

The free dive starts at 1.2 m (4 ft) and ends when your depth is less than 0.9 m (3 ft).

Free mode has the following settings:

- Depth notifications (see 3.14.4.1. *Depth notifications*)

- Depth alarm (see 3.12. *Depth alarm*)
- Dive time alarm (see 3.16. *Dive time alarm*)
- Surface timer (see 3.23. *Surface and no-fly time*)
- Sample rate (see 3.20. *Sample rate*)

3.14.4.1. Depth notifications

You can define up to five independent depth notifications for freediving, for example, to alert you to start free falling or mouth filling. Each notification has a defined depth and can be turned on or off.

When you reach the notification depth, the backlight blinks and the low priority audible alarm sounds.

To define depth notifications:

1. While in **Free** mode, keep [DOWN] pressed.
2. Press [SELECT] to enter the **Depth Notify** settings.
3. Scroll through the notifications with [DOWN] or [UP] and enter a notification with [SELECT] .
4. Press [DOWN] or [UP] to toggle the notification On/Off and confirm with [SELECT] .
5. Adjust the depth with [DOWN] or [UP] and confirm with [SELECT] .
6. Scroll to the next notification to modify or press [MODE] to exit.

3.14.4.2. Surface countdown timer

While freediving, you can use the surface countdown timer to help you prepare yourself for you next dive. Suunto D6i starts the countdown as soon as you reach 1.2 m (4 ft).

To set the surface countdown timer:

1. While in **Free** mode, keep [DOWN] pressed.
2. Press [UP] to scroll to **Surf. Time Notify**.
3. Press [DOWN] or [UP] to toggle the timer on and confirm with [SELECT] .
4. Adjust the countdown duration with [DOWN] or [UP] and conform with [SELECT] .
5. Press [MODE] to exit.

3.15. Dive planning mode

The dive planning mode **PLAN NoDeco** can be used to plan a dive that does not require decompression. You enter the depth of your upcoming dive, and Suunto D6i calculates the maximum time you can stay at that depth without requiring decompression stops.

The dive plan takes into account:

- any calculated residual nitrogen
- dive history from the past four days

To plan dives:

1. Press [MODE] until you see **PLAN NODEC**.
2. The display briefly shows your remaining desaturation time before continuing to the planning display.
3. Press [DOWN] or [UP] to scroll your upcoming dive depths. The depth moves in 3 m (10 ft) increments from 9 m – 45 m (30 ft – 150 ft). The no-decompression time limit for the

selected depth is shown in the center of the display. If you have dived at least once with Suunto D6i, the **SURFTIME +** field appears. You can adjust the surface time with [UP].

4. Between consecutive dives, you can press [SELECT] to adjust surface time.
5. Press [MODE] to exit.

 **NOTE:** The dive planning mode is disabled if the dive computer is in an error state (see 3.17. Error state (algorithm lock)) or if the dive mode is off or in **Gauge** mode.

3.16. Dive time alarm

The dive time alarm can be activated and used for several purposes to add to your diving safety. It is simply a countdown timer in minutes.

To set the dive time alarm:

1. While in a relevant dive mode, keep [DOWN] pressed.
2. Press [DOWN] or [UP] to scroll to **ALARM TIME**.
3. Press [UP] to toggle the alarm on and press [SELECT] to confirm.
4. Adjust the duration with [UP] or [DOWN] and accept with [SELECT].
5. Press [MODE] to exit.

3.17. Error state (algorithm lock)

Suunto D6i has warning indicators that alert you to react to certain situations that would significantly increase the risk of DCS. If you do not respond to these warnings, Suunto D6i enters an error state and shows **Er** on the display. This indicates that the risk of DCS has greatly increased.

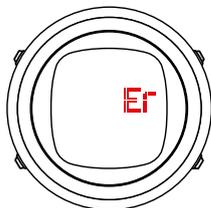

If you omit decompression stops for longer than three (3) minutes, the RGBM algorithm is locked for 48 hours. When the algorithm is locked, no algorithm information is available and **ER** is shown instead. Locking the algorithm is a safety feature, highlighting that the algorithm information is no longer valid.

In such a condition, you should descend back below the ceiling level to continue the decompression. If you fail to do so within three (3) minutes, Suunto D6i locks the algorithm calculation and displays **ER** instead, as shown below. Note that the ceiling value is no longer present.

In this state, you significantly increase your risk of decompression sickness (DCS). Decompression information is not available for the next 48 hours after surfacing.

It is possible to dive with the device when the algorithm is locked, but instead of the decompression information, **ER** is shown.

If you dive again in this error state, the algorithm lock time resets to 48 hours when you surface.

3.18. Personal and altitude adjustments

There are several factors that can affect your susceptibility to DCS. Such factors vary between divers and from one day to another.

The personal factors which tend to increase the possibility of DCS include:

- exposure to cold water - less than 20°C (68 °F)
- below average physical fitness level
- fatigue
- dehydration
- stress
- obesity
- patent foramen ovale (PFO)
- exercise before or after dive

The three-step personal setting can be used to adjust the algorithm to fit your DCS susceptibility.

| Personal adjustment | Explanation |
|---------------------|--|
| 0 | Ideal conditions (default value). |
| 1 | Conservative. Some risk factors or conditions exist. |
| 2 | More conservative. Several risk factors or conditions exist. |

In addition to the personal setting, Suunto D6i can be adjusted for diving at different altitudes. This adjusts the decompression calculation according to the selected altitude adjustment.

| Altitude adjustment | Explanation |
|---------------------|----------------------------------|
| 0 | 0 – 300 m (0 – 980 ft) (default) |
| 1 | 300 – 1500 m (980 – 4900 ft) |
| 2 | 1500 – 3000 m (4900 – 9800 ft) |

To change the personal and altitude adjustment settings:

1. While in a dive mode, keep [DOWN] pressed.
2. Press [SELECT] to enter **Personal Altitude** settings.
3. Press [UP] to change the **Personal** adjustment and confirm with [SELECT].
4. Press [UP] to change the **Altitude** adjustment and confirm with [SELECT].
5. Press [MODE] to exit.

 **WARNING:** *Traveling to a higher altitude can temporarily cause changes to the equilibrium of dissolved nitrogen in the body. It is recommended that you acclimatize to the new altitude by waiting at least three (3) hours before diving.*

3.19. Safety stops and deepstops

Safety stops are widely considered good diving practice and are a critical part of most dive tables. The reasons for performing a safety stop include: reducing sub-clinical DCI, microbubble reduction, ascent control, and orientation before surfacing.

Suunto D6i displays two different types of safety stops: recommended and mandatory.

With every dive over 10 meters (30 feet), there is a three-minute countdown for the recommended safety stop. This stop is taken in the 3-6 m (10-20 ft) range. Suunto D6i shows a STOP icon and a three-minute countdown.

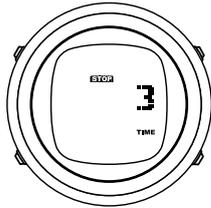

 **NOTE:** When deepstops are enabled, the length of mandatory safety stops is indicated in seconds.

When the ascent rate exceeds 10 m (33 ft) per minute for more than five consecutive seconds, the microbubble build-up may be more than is allowed for in the decompression model.

In this situation, Suunto D6i adds a mandatory safety stop to the dive. The time of this stop depends on the speed violation of the ascent rate.

The STOP icon is shown in the display. When you reach the depth zone between 6 m and 3 m (18 ft and 9 ft) the following is displayed:

1. **CEILING** and **STOP**
2. Ceiling depth
3. Safety stop time



Wait at the ceiling until the mandatory safety stop warning disappears.

 **WARNING:** NEVER ASCEND ABOVE THE CEILING! You must not ascend above the ceiling during your decompression. In order to avoid doing so by accident, you should stay somewhat below the ceiling.

Deepstops activate when you dive deeper than 20 m (65.6 ft).

If the dive timer is on the screen when deepstop activates, the timer is replaced with deepstop.

After deepstop is over, the user can change between deepstop and the timer by long pressing the MODE button.

Deepstops are presented the same way as safety stops. Suunto D6i notifies you that you are in the deepstop area by displaying:

- **CEILING** in the top
- **DEEPSTOP** in the center row
- Stop depth
- Countdown timer



Deepstop is on by default in **Air** and **Nitrox** modes. To turn deepstop off:

1. While in a dive mode, keep [DOWN] pressed.
2. Press [DOWN] to scroll to **Deepstop** and enter with [Select] .
3. Press [UP] to toggle on/off.
4. Press [MODE] to exit.

3.20. Sample rate

The sample rate controls how often information from the dive is saved to the active log. The default sample rate is 20 seconds in air and nitrox modes, and 2 seconds in free dive mode.

To change the sample rate:

1. While in a dive mode, keep [DOWN] pressed.
2. Press [UP] to scroll to **Sample Rate** and press [SELECT] .
3. Press [DOWN] or [UP] to change the rate and confirm with [SELECT] .
4. Press **MODE** to exit.

The sample rate options in air and nitrox modes are: 10, 20, 30 and 60 seconds.

The sample rate options in free dive mode are: 1, 2 and 5 seconds.

3.21. Software version

You can check the software version and battery status of Suunto D6i under the general settings.

1. While in time mode, keep [DOWN] pressed.
2. Press [UP] to scroll to **Version** and press [SELECT] .
3. The software version is displayed along with the battery voltage.

3.22. Stopwatch

The stopwatch can be used to measure elapsed and split times.

To activate the stopwatch:

1. While in time mode, scroll through the bottom row view by pressing [UP] or [DOWN] until the stopwatch is displayed.

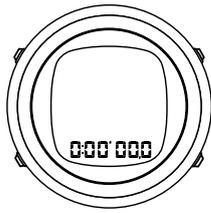

2. Press [SELECT] to start/stop the stopwatch.
3. Press [DOWN] to take split times.
4. Keep [SELECT] pressed to reset the stopwatch.

After stopping the stopwatch, you can scroll through the split times with [DOWN].

You can also use the stopwatch while diving for various timing purposes. To activate the stopwatch in dive mode, keep [MODE] pressed.

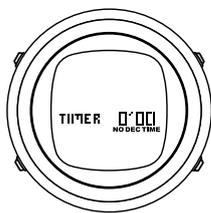

Start and stop the stopwatch by pressing [SELECT].

 **NOTE:** If a deepstop activates while you are using the stopwatch, the timer field is not visible.

3.23. Surface and no-fly time

Once back at the surface, Suunto D6i continues to provide post-dive safety information and alarms. If, after your dive, you need to wait until flying, the no-fly symbol displays in all modes.



To access further information about your surface and no-fly times, enter dive mode.

Suunto D6i shows the time since you surfaced in the **Surf t.** field. The airplane symbol indicates that you should not fly. The countdown until you will be safe to fly is shown in the **No Fly** field.

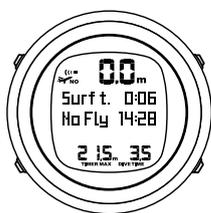

No-fly time is always at least 12 hours and equals desaturation time when it is more than 12 hours. For desaturation times shorter than 70 minutes, the no-fly time is not displayed.

If decompression is omitted during a dive so that Suunto D6i enters error state (see 3.17. *Error state (algorithm lock)*), the no-fly time is always 48 hours.

If a dive is done in **Gauge** mode (bottom timer), the no-fly time is 48 hours.

⚠ WARNING: YOU ARE ADVISED TO AVOID FLYING ANY TIME THE COMPUTER COUNTS DOWN THE NO-FLY TIME. ALWAYS ACTIVATE THE COMPUTER TO CHECK THE REMAINING NO-FLY TIME PRIOR TO FLYING! Flying or traveling to a higher altitude within the no-fly time can greatly increase the risk of DCS. Review the recommendations given by Divers Alert Network (DAN). There can never be a flying-after-diving rule that is guaranteed to completely prevent decompression sickness!

The Divers Alert Network (DAN) recommends the following on no-fly times:

- A minimum surface interval of 12 hours would be required in order to be reasonably assured a diver will remain symptom free upon ascent to altitude in a commercial jetliner (altitude up to 2,400 m (8,000 ft)).
- Divers who plan to make daily, multiple dives for several days, or make dives that require decompression stops, should take special precautions and wait for an extended interval beyond 12 hours before a flight. Further, the Undersea and Hyperbaric Medical Society (UHMS) suggests divers using standard air cylinders and exhibiting no symptoms of decompression sickness wait 24 hours after their last dive to fly in an aircraft with cabin pressure up to 2,400 m (8,000 ft). The only two exceptions to this recommendation are:
 - If a diver has less than two (2) hours total accumulated dive time in the last 48 hours, a 12 hour surface interval before flying is recommended.
 - Following any dive that required a decompression stop, flying should be delayed for at least 24 hours, and if possible, for 48 hours.

Suunto recommends that flying is avoided until all the DAN and UHMS guidelines, as well as the dive computer's no-fly conditions, are satisfied.

3.24. Dive numbering

If the Suunto D6i has not counted the no-fly time down to zero, then repetitive dives belong to the same dive series.

Within each series, the dives are given numbers. The first dive of the series is **DIVE 1**, the second **DIVE 2**, and so on.

If you start a new dive with less than five (5) minutes at the surface, Suunto D6i treats the new dive as part of the previous dive. The dive time continues where it left off.

After five (5) minutes or more at the surface, any new dives are part of a repetitive dive series. The dive counter displayed in the planning mode adds one to each new dive in the repetitive series.

The planning mode allows you to review the no-decompression limits on the next dive in a series.

3.25. Suunto RGBM

Suunto's decompression model development originates from the 1980s when Suunto implemented Bühlmann's model based on M-values in Suunto SME. Since then research and development has been ongoing with the help of both external and internal experts.

In the late 1990s, Suunto implemented Dr. Bruce Wienke's RGBM (Reduced Gradient Bubble Model) bubble model to work with the earlier M-value based model. The first commercial products with the feature were the iconic Suunto Vyper and Suunto Stinger. With these products the improvement of diver safety was significant as they addressed a number of diving circumstances outside the range of dissolved-gas-only models by:

- Monitoring continuous multiday diving
- Computing closely spaced repetitive diving
- Reacting to a dive deeper than the previous dive
- Adapting to rapid ascents which produce high microbubble (silent-bubble) build-up
- Incorporating consistency with real physical laws for gas kinetics

The Suunto RGBM predicts both dissolved and free gas in the blood and tissues of divers. It is a significant advancement on the classic Haldane models, which do not predict free gas. The Suunto RGBM provides additional safety through its ability to adapt to a variety of situations and dive profiles.

3.25.1. Diver Safety

Because any decompression model is purely theoretical and does not monitor the actual body of a diver, no decompression model can guarantee the absence of DCS. Experimentally it has been shown that the body adapts to decompression to some degree when diving is constant and frequent. Personal adjustment settings are available for divers who dive constantly and are ready to accept greater personal risk.

⚠ CAUTION: *Always use the same personal and altitude adjustment settings for the actual dive and for the planning. Increasing the personal adjustment setting from the planned setting as well as increasing the altitude adjustment setting can lead to longer decompression times deeper and thus to larger required gas volume. You can run out of breathing gas underwater if the personal adjustment setting has been changed after dive planning.*

3.25.2. Altitude diving

The atmospheric pressure is lower at high altitudes than at sea level. After traveling to a higher altitude, you will have additional nitrogen in your body, compared to the equilibrium situation at the original altitude. This 'additional' nitrogen is released gradually over time and equilibrium is restored. It is recommended that you acclimatize to a new altitude by waiting at least three hours before making a dive.

Before high-altitude diving, you need to adjust the altitude settings of your dive computer so that the calculations take into account the high altitude. The maximum partial pressures of nitrogen allowed by the mathematical model of the dive computer are reduced according to the lower ambient pressure.

As a result, the allowed no decompression stop limits are considerably reduced.

⚠ WARNING: *SET THE CORRECT ALTITUDE SETTING! When diving at altitudes greater than 300 m (1000 ft), the altitude setting must be correctly selected in order for the computer to calculate the decompression status. The dive computer is not intended for use at altitudes greater than 3000 m (10000 ft). Failure to select the correct altitude setting or diving above the maximum altitude limit will result in erroneous dive and planning data.*

3.25.3. Oxygen exposure

The oxygen exposure calculations are based on currently accepted exposure time limit tables and principles.

The dive computer calculates separately the Central Nervous System oxygen toxicity (CNS) and the Pulmonary Oxygen toxicity, the latter measured by the addition of Oxygen Toxicity Units (OTU).

Both fractions are scaled so that the diver's maximum tolerated exposure for each is 100%.

Suunto D6i does not display CNS% or OTU% but instead displays the larger of the two in the **OLF%** field. **OLF%** value is the Oxygen limit fraction or Oxygen Toxicity Exposure.

For example, if the diver's maximum tolerated exposure for CNS% is 85% and the maximum tolerated exposure for OTU% is 80% the **OLF%** displays the largest scaled value, here 85%.

Oxygen related information displayed by the dive computer is also designed to ensure that all warnings and displays occur at the appropriate phases of a dive.

⚠ WARNING: *WHEN THE OXYGEN LIMIT FRACTION INDICATES THAT THE MAXIMUM LIMIT IS REACHED, YOU MUST IMMEDIATELY TAKE ACTION TO REDUCE OXYGEN EXPOSURE. Failure to take action to reduce oxygen exposure after a CNS/OTU warning is given can rapidly increase the risk of oxygen toxicity, injury, or death.*

3.26. Tank pressure

When using the optional Suunto Wireless Transmitter, the pressure of your tank is shown in the lower left of the display.

Whenever you start a dive, the remaining air time calculation begins. After 30-60 seconds, the first estimation of remaining air time is shown in the left center of the display.

The calculation is always based on the actual pressure drop in your tank and automatically adapts to your tank size and current air consumption.



The change in your air consumption is based on constant one second interval pressure measurements over periods of 30–60 seconds. An increase in air consumption decreases the remaining air time rapidly, while a drop in air consumption increases the air time slowly. In this way, an overly optimistic air time estimate, caused by a temporary drop in air consumption, is avoided.

The remaining air time calculation includes a 35 bar (500 psi) safety reserve. This means that when the instrument shows the air time to be zero, there is still a small reserve.

📖 NOTE: *Filling your BCD affects the air time calculation due to the temporary increase in air consumption.*

The remaining air time is not displayed when either deepstops or the decompression ceiling has been activated. You can check remaining air time by keeping [DOWN] pressed.

Temperature changes affect the tank pressure and consequently the air time calculation.

Low air pressure warnings

The dive computer warns you with two (2) audible double beeps and a blinking pressure display when the tank pressure reaches 50 bar (700 psi).

Two (2) double beeps sound when the tank pressure reaches the defined alarm pressure and when the remaining time reaches zero.

3.26.1. Wireless transmission

To enable wireless transmission of tank pressure data to Suunto D6i requires:

1. Installation of Suunto Wireless Transmitter onto your regulator.
2. Pairing the transmitter to your Suunto D6i.
3. Enabling the wireless integration in your Suunto D6i settings.

The transmitter enters power saving mode with slower data transmission rate if the tank pressure remains unchanged for more than five (5) minutes.

The optional transmitter sends out a low battery (**batt**) warning when its battery voltage is getting low. This is shown intermittently instead of the pressure reading. When you get this warning, the tank pressure transmitter's battery needs to be replaced.

3.26.2. Installing and pairing transmitter

When purchasing the Suunto Wireless Transmitter, we strongly recommend that you have your Suunto representative attach the transmitter to the first stage of your regulator.

The unit needs to be undergo a pressure test after installation and typically this requires a trained technician.

In order to receive wireless data, the transmitter and the Suunto D6i need to be paired.

The wireless transmitter activates when the tank pressure exceeds 15 bar (300 psi). The transmitter then starts sending pressure data together with a code number.

When your Suunto D6i is within 0.3 m (1 ft) of the transmitter, it receives and stores that code. The transmitter and Suunto D6i are now paired. Suunto D6i will then display the pressure data it receives with this code. This coding procedure prevents data mix-up from other divers also using a Suunto Wireless Transmitter.



NOTE: *The pairing procedure normally only needs to be done once. You may need to redo the pairing procedure if another diver in your group uses the same code.*

To assign a new transmitter code:

1. Slowly open the tank valve fully to pressurize the system.
2. Immediately close the tank valve.
3. Quickly depressurize the regulator so that the pressure is reduced to less than 10 bar (145 psi).
4. Wait about 10 seconds, and slowly open the tank valve again to re-pressurize above 15 bar (300 psi).

The transmitter assigns a new code automatically. To re-pair the transmitter with your Suunto D6i:

1. While in a dive mode other than **Free** or **Gauge**, keep [DOWN] pressed to enter the settings.
2. Press [DOWN] to scroll to **Tank Press Pairing** and press **SELECT**.
3. Make sure **TANK PRESS PAIRING** is set to **ON** and press [SELECT] .
4. A code number is displayed. Press [UP] to clear the code.
5. Press [SELECT] .

6. Press [MODE] to exit.

With the system pressurized to above 15 bar (300 psi), bring your Suunto D6i close to the transmitter. When pairing is completed, the dive computer displays the new code number and the transmitted tank pressure.

The wireless transmitter indicator is displayed every time a valid signal is received.

3.26.3. Transmitted data

After pairing, your Suunto D6i receives tank pressure data from the transmitter.

Any time the Suunto D6i receives a signal, one of the following symbols is shown in the lower left corner of the display.

| Display | Indication |
|--|--|
| Cd:- | No code stored, the dive computer is ready for pairing with the transmitter. |
| Cd:10 | Current code number. Code number can be from 01 to 40. |
| - - - | The flash symbol is blinking. Pressure reading exceeds allowed limit (over 360 bar (5220 psi)). |
| Last pressure reading followed by no conn | Tank pressure data has not been updated for 1 minute. See below for solutions. |
| - - - followed by no conn | Tank pressure data has not been updated for 5 minutes. See below for solutions. |
| no conn | Text no conn is displayed when the unit receives no data from the transmitter. The pressure reading has not been updated for over a minute. The last received pressure blinks on and off. The flash symbol is not displayed. This state may be caused by the : <ol style="list-style-type: none"> 1. Transmitter being out of range (>1.2 m (4 ft)) 2. Transmitter is in power saving mode 3. Transmitter is using a different code. To correct this: Activate the transmitter by breathing off the regulator. Bring the dive computer closer to the transmitter and check if the flash symbol appears. If it does not, re-pair the transmitter to get a new code. |
| batt | Pressure transmitter battery voltage is low. Change the transmitter battery! |

3.26.4. Tank pressure alarm

There are two tank pressure alarms. The first is fixed at 50 bar (700 psi) and cannot be changed.

The second is user configurable. It can be turned on or off and can be used for a pressure range of 10–200 bar (200-3000 psi).

To set the tank pressure alarm value:

1. While in a dive mode, keep [DOWN] pressed to enter settings.
2. Press [DOWN] to scroll to **Tank Press Alarm** and press [SELECT] .
3. Press [UP] to turn the alarm on and confirm with [SELECT] .
4. Adjust the pressure level with [UP] or [DOWN] and confirm with [SELECT] .
5. Press [MODE] to exit.

3.27. Tones

Device tones can be turned on or off. When tones are off, there are no audible alarms.

To set tones:

1. While in time mode, keep [DOWN] pressed.
2. Press [DOWN] or [UP] to scroll to **Tones** and press [SELECT] .
3. Press [DOWN] or [UP] to toggle on/off and confirm with [SELECT] .
4. Press [MODE] to exit.

3.28. Water contact

The water contact is located on the side of the case. When submerged, the water contact poles are connected by the conductivity of the water. Suunto D6i switches to dive state when water is detected and the depth gauge senses water pressure at 1.2 m (4 ft).

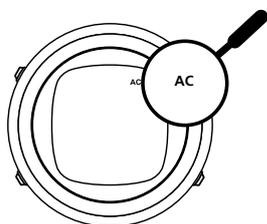

The **AC** is shown until the water contact deactivates. It is important to keep the water contact area clean. Contamination or dirt can prevent automatic activation/deactivation.

 **NOTE:** *Moisture build-up around the water contact may cause the dive mode to activate. This can happen, for example, when washing your hands or sweating. To save battery power, deactivate the water contact by cleaning it and/or drying it with a soft towel.*

4. Care and support

4.1. Handling guidelines

The Suunto D6i dive computer is a sophisticated precision instrument. Although it is designed to withstand the rigors of diving, you must treat it with the same proper care and caution as any other precision instrument.

Handle the unit with care – do not knock or drop it.

Do not fasten the strap of your dive computer too tightly. You should be able to insert your finger between the strap and your wrist.

After use, rinse it with fresh water, mild soap, and carefully clean the housing with a moist soft cloth or chamois.

Use only original Suunto accessories - damage caused by non-original accessories is not covered by warranty.

Keep the water contact and depth sensors areas on the sides of the watch clean using fresh water and a soft brush, such as a toothbrush.

Never try to open the case of the dive computer. Have your Suunto D6i serviced every two years or after 200 dives (whichever comes first) by an authorized Suunto service center.

This service includes a general operational check, replacement of the battery, and water resistance check. The service requires special tools and training. Do not attempt to do any servicing yourself.

Should moisture appear inside the case or battery compartment, immediately have the instrument checked by your Suunto service center.

The optional scratch guard for Suunto D6i is designed to help prevent the display from getting scratched. Scratch guards can be purchased separately from your authorized Suunto dealer.

Should you detect scratches, cracks or other such flaws on the display that may impair its durability, immediately contact your authorized Suunto dealer.

Protect the unit from shock, extreme heat, direct sunlight, and chemicals.

Store your dive computer in a dry place when you are not using it.

4.2. Water resistance

Suunto D6i is water resistant to 150 meters (492 ft) in compliance with the dive watch standard ISO 6425.

 **WARNING:** *Water resistance is not equivalent to maximum operating depth. The maximum operating depth of this dive computer is 120 meters (393 ft).*

To maintain water resistance, it is recommended to:

- never use the device for other than intended use.
- contact an authorized Suunto service center, distributor or retailer for any repairs.
- keep the device clean from dirt and sand.
- never attempt to open the case yourself.
- avoid subjecting the device to rapid air and water temperature changes.

- always clean your device with fresh water if subjected to salt water.
- never knock or drop the device.

4.3. Battery replacement

Suunto D6i displays a battery symbol as a warning when the power gets too low. When this happens, your Suunto D6i should not be used for diving until the battery has been replaced.

Contact an authorized Suunto service center for battery replacement. It is imperative that the change is made in a proper manner to avoid any leakage of water into the battery compartment or computer.

Defects caused by improper battery installation are not covered by the warranty.

All history and logbook data, as well as the altitude, personal and alarm settings, remain in the dive computer memory after the battery change. Other settings revert back to default values.

5. Reference

5.1. Technical specifications

Dimensions and weight

- Length: 50 mm (1.97 in)
- Width: 50 mm (1.97 in)
- Height: 16.0 mm (0.61 in)
- Weight: 113 g (3.98 oz)

Operating conditions

- Water resistance: 150 m (492 ft) (complying with ISO 6425)
- Normal altitude range: 0 to 3,000 m (0 to 10,000 ft) above sea level
- Operating temperature: 0 °C to 40 °C (32 °F to 104 °F)
- Storage temperature: -20 °C to +50°C (-4 °F to +122 °F)
- Maintenance cycle: 200 dives or two years, whichever comes first

Depth gauge

- Temperature compensated pressure sensor
- Accurate to 100 m (328 ft) complying with EN 13319
- Depth display range: 0 to 300 m (0 to 984 ft)
- Resolution: 0.1 m from 0 to 100 m (1 ft from 0 to 328 ft)

Temperature display

- Resolution: 1 °
- Display range: -20 °C to +50 °C (-4 °F to +122 °F)
- Accuracy: ± 2 °C (± 3.6 °F) within 20 minutes of temperature change

Nitrox mode

- Oxygen: 21–99%
- Partial pressure of oxygen (pO₂): 0.2 – 3.0
- Oxygen Limit Fraction: 0–200% with 1% resolution
- Gas mixtures: up to 3

Other displays

- Dive time: 0 to 999 min
- Surface time: 0 to 99 h 59 min
- Dive counter: 0 to 999 for repetitive dives
- No-decompression time: 0 to 99 min (– after 99)
- Ascent time: 0 to 999 min (– after 999)
- Ceiling depths: 3.0 to 150 m (10 to 492 ft)

Calendar clock

- Accuracy: ± 25 s/month (at 20 °C (68 °F))
- 12/24 h display

Compass

- Accuracy: $\pm 15^\circ$
- Resolution: 1°
- Max. tilt: 45 degrees
- Balance: global

Stopwatch

- Accuracy: 1 second
- Display range: 0'00 – 99'59
- Resolution: 1 second

Logbook

- Sample rate in air and nitrox modes: default 20 seconds
- Sample rate in free diving mode: default 2 seconds
- Memory capacity: approximately 60 hours with 20-second recording interval and without transmitter data. With transmitter data, the capacity is approximately 40 hours. In free dive mode (2-second recording interval), maximum capacity is 3 hours.

Tissue calculation model

- Suunto RGBM
- Maximum depth of operation: 120 m (393 ft)

Radio transceiver

- Frequency band: single channel 5.3 kHz
- Maximum output power: 110 mW
- Range: 1.5 m / 4.9 ft

Manufacturer

Suunto Oy

Tammiston kauppatie 7 A

FI-01510 Vantaa FINLAND

5.2. Compliance

5.2.1. CE

Hereby, Suunto Oy, declares that the radio equipment type DW172 is in compliance with Directive 2014/53/EU. The full text of the EU declaration of conformity is available at the following internet address: www.suunto.com/EUconformity.

5.2.2. EU depth gauge standard

EN13319 is a European diving depth gauge standard. Suunto dive computers are designed to comply with this standard.

5.3. Trademark

Suunto D6i, its logos, and other Suunto brand trademarks and made names are registered or unregistered trademarks of Suunto Oy. All rights are reserved.

5.4. Patent notice

This product is protected by pending patent applications and their corresponding national rights: US 5,845,235, US 7,349,805, US 8,660,826. Additional patent applications may be filed.

5.5. International Limited Warranty

Suunto warrants that during the Warranty Period Suunto or a Suunto Authorized Service Center (hereinafter Service Center) will, at its sole discretion, remedy defects in materials or workmanship free of charge either by a) repairing, or b) replacing, or c) refunding, subject to the terms and conditions of this International Limited Warranty. This International Limited Warranty is valid and enforceable regardless of the country of purchase. The International Limited Warranty does not affect your legal rights, granted under mandatory national law applicable to the sale of consumer goods.

Warranty Period

The International Limited Warranty Period starts at the date of original retail purchase.

The Warranty Period is two (2) years for Products and Dive wireless transmitters unless otherwise specified.

The Warranty Period is one (1) year for accessories including but not limited to wireless sensors and transmitters, chargers, cables, rechargeable batteries, straps, bracelets and hoses.

Exclusions and Limitations

This International Limited Warranty does not cover:

1. a. normal wear and tear such as scratches, abrasions, or alteration of the color and/or material of non-metallic straps, b) defects caused by rough handling, or c) defects or damage resulting from use contrary to intended or recommended use, improper care, negligence, and accidents such as dropping or crushing;
2. printed materials and packaging;

3. defects or alleged defects caused by use with any product, accessory, software and/or service not manufactured or supplied by Suunto;
4. non-rechargeable batteries.

Suunto does not warrant that the operation of the Product or accessory will be uninterrupted or error free, or that the Product or accessory will work with any hardware or software provided by a third party.

This International Limited Warranty is not enforceable if the Product or accessory:

1. has been opened beyond intended use;
2. has been repaired using unauthorized spare parts; modified or repaired by unauthorized Service Center;
3. serial number has been removed, altered or made illegible in any way, as determined at the sole discretion of Suunto; or
4. has been exposed to chemicals including but not limited to sunscreen and mosquito repellents.

Access to Suunto warranty service

You must provide proof of purchase to access Suunto warranty service. You must also register your product online at www.suunto.com/mysuunto to receive international warranty services globally. For instructions how to obtain warranty service, visit www.suunto.com/warranty, contact your local authorized Suunto retailer, or call Suunto Contact Center.

Limitation of Liability

To the maximum extent permitted by applicable mandatory laws, this International Limited Warranty is your sole and exclusive remedy and is in lieu of all other warranties, expressed or implied. Suunto shall not be liable for special, incidental, punitive or consequential damages, including but not limited to loss of anticipated benefits, loss of data, loss of use, cost of capital, cost of any substitute equipment or facilities, claims of third parties, damage to property resulting from the purchase or use of the item or arising from breach of the warranty, breach of contract, negligence, strict tort, or any legal or equitable theory, even if Suunto knew of the likelihood of such damages. Suunto shall not be liable for delay in rendering warranty service.

5.6. Copyright

© Suunto Oy 10/2012. All rights reserved. Suunto, Suunto product names, their logos and other Suunto brand trademarks and names are registered or unregistered trademarks of Suunto Oy. This document and its contents are proprietary to Suunto Oy and are intended solely for the use of clients to obtain knowledge and information regarding the operation of Suunto products. Its contents shall not be used or distributed for any other purpose and/or otherwise communicated, disclosed or reproduced without the prior written consent of Suunto Oy. While we have taken great care to ensure that information contained in this documentation is both comprehensive and accurate, no warranty of accuracy is expressed or implied. This document content is subject to change at any time without notice. The latest version of this documentation can be downloaded at www.suunto.com.

5.7. Terms

| Term | What it means |
|---------------------|--|
| Altitude dive | A dive made at an elevation greater than 300 m (1000 ft) above sea level. |
| Ascent rate | The speed at which the diver ascends toward the surface. |
| Ascent time | The minimum amount of time needed to reach the surface on a decompression stop dive. |
| Ceiling | On a decompression stop dive, the shallowest depth to which a diver may ascend based on computed inert gas load. |
| CNS | Central nervous system toxicity. Toxicity is caused by oxygen. Can cause a variety of neurological symptoms. The most important of which is an epileptic-like convulsion which can cause a diver to drown. |
| CNS% | Central nervous system toxicity limit fraction. |
| Compartment | See "Tissue group". |
| DM5 | Suunto DM5 with Movescount, a software for managing your dives. |
| Decompression | Time spent at a decompression stop, or range, before surfacing, to allow absorbed nitrogen to escape naturally from tissues. |
| Decompression range | On a decompression stop dive, the depth range between the floor and the ceiling within which a diver must stop for some time during ascent. |
| DCS | Decompression sickness/illness. Any of a variety of maladies resulting either directly or indirectly from the formation of nitrogen bubbles in tissues or body fluids, as a result of inadequately controlled decompression. |
| Dive series | A group of repetitive dives between which the dive computer indicates some nitrogen loading is present. When nitrogen loading reaches zero the dive computer deactivates. |
| Dive time | Elapsed time between leaving the surface to descend, and returning to the surface at the end of a dive. |
| Floor | The deepest depth during a decompression stop dive at which decompression takes place. |
| He% | Helium percentage or helium fraction in the breathing gas. |
| MOD | Maximum operating depth of a breathing gas is the depth at which the partial pressure of oxygen (PO ₂) of the gas mix exceeds a safe limit. |

| Term | What it means |
|--|--|
| Multi level dive | A single or repetitive dive that includes time spent at various depths and whose no decompression limits are therefore not determined solely by the maximum depth attained. |
| Nitrox (Nx) | In sports diving, refers to any mix with a higher fraction of oxygen than standard air. |
| No deco (No decompression stop time) | Any dive which permits a direct, uninterrupted ascent to the surface at any time. |
| No dec time | Abbreviation for no decompression time limit. |
| OC | Open-circuit. Scuba that exhausts all exhaled gas. |
| OLF% | Oxygen limit fraction. The diver's current oxygen toxicity exposure. |
| O ₂ % | Oxygen percentage or oxygen fraction in the breathing gas. Standard air has 21% oxygen. |
| Partial pressure of oxygen (O ₂) | Limits the maximum depth to which the nitrox mixture can be safely used. The maximum partial pressure limit for enriched air diving is 1.4 bar (20 psi). The contingency partial pressure limit is 1.6 bar (23 psi). Dives beyond this limit risk immediate oxygen toxicity. |
| Reduced gradient bubble model (RGBM) | Modern algorithm for tracking both dissolved and free gas in divers. |
| Repetitive dive | Any dive whose decompression time limits are affected by residual nitrogen absorbed during previous dives. |
| Residual nitrogen | The amount of excess nitrogen remaining in a diver after one or more dives. |
| Scuba | Self-contained underwater breathing apparatus. |
| Surface time | Elapsed time between surfacing from a dive and beginning a descent for the subsequent dive. |
| Tissue group | Theoretical concept used to model bodily tissues for the construction of decompression tables or calculations. |
| Trimix | A breathing gas mix of helium, oxygen and nitrogen. |

Index

| | | | |
|--------------------------|---------|------------------------------|-------------|
| AC symbol..... | 40 | handling..... | 41 |
| Activation..... | 11 | high-altitude diving..... | 36 |
| Air..... | 12 , 26 | Icon..... | 7 |
| Alarm..... | 18 | indicators..... | 12 |
| Alarms..... | 13 | installing..... | 38 |
| Altitude adjustment..... | 31 | Logbook..... | 24 |
| Apnea timer..... | 15 | Memory mode..... | 24 |
| ascent time..... | 20 | Modes..... | 7 , 26 |
| Battery..... | 12 , 42 | Nitrox..... | 26 |
| Bearing..... | 20 | No-fly time..... | 34 |
| Calibrate..... | 19 | Notifications..... | 13 |
| care..... | 41 | Oxygen toxicity..... | 36 |
| change modes..... | 7 | pairing..... | 38 |
| Compass..... | 19, 20 | Personal adjustment..... | 31 |
| contrast..... | 23 | Plan..... | 35 |
| declination..... | 19 | pre-checks..... | 11 |
| Decompression..... | 35 , 36 | RGBM..... | 35 |
| decompression dive..... | 20 | Safety..... | 36 |
| decompression stop..... | 20 | safety stop..... | 16 , 20, 32 |
| deepstop..... | 20 , 32 | software version..... | 33 |
| Display..... | 7 , 23 | surface countdown timer..... | 29 |
| Dive..... | 26 | Surface time..... | 34 |
| Dive modes..... | 26, 28 | Tank pressure..... | 38 |
| Dive planning..... | 29 | Time..... | 17 |
| Diving mode..... | 12 | Time mode..... | 17 |
| Er..... | 30 | timeout..... | 19 |
| Error State..... | 30 | transmitted data..... | 39 |
| Free..... | 28 | units..... | 17 |
| Free mode..... | 29 | Warnings..... | 13 |
| Gauge..... | 28 | Wireless Transmitter..... | 12 , 38, 39 |
| Glossary..... | 47 | | |



SUUNTO CUSTOMER SUPPORT

1. www.suunto.com/support
www.suunto.com/mysuunto
2.

| | |
|---------------------------|--------------------------|
| AUSTRALIA (24/7) | +61 1800 240 498 |
| AUSTRIA | +43 720 883 104 |
| CANADA (24/7) | +1 855 624 9080 |
| CHINA | +86 400 661 1646 |
| CHINA - Hong Kong | +852 58060687 |
| FINLAND | +358 9 4245 0127 |
| FRANCE | +33 4 81 68 09 26 |
| GERMANY | +49 89 3803 8778 |
| ITALY | +39 02 9475 1965 |
| JAPAN | +81 3 4520 9417 |
| NETHERLANDS | +31 1 0713 7269 |
| NEW ZEALAND (24/7) | +64 9887 5223 |
| RUSSIA | +7 499 918 7148 |
| SPAIN | +34 91 11 43 175 |
| SWEDEN | +46 8 5250 0730 |
| SWITZERLAND | +41 44 580 9988 |
| UK (24/7) | +44 20 3608 0534 |
| USA (24/7) | +1 855 258 0900 |

© Suunto Oy

Suunto is a registered trademark of Suunto Oy. All Rights reserved.